

MGTR-II

Megger GPS Timing Reference-Mark II



- **Small and lightweight**
- **Easy to use programmable output pulse for synchronized end-to-end testing**
- **100 ns accuracy within minutes of startup, 12-channel GPS timing receiver**
- **Near-Rubidium stability during temporary GPS signal loss**
- **IRIG-B serial time code output**
- **Standard one pulse-per-second (PPS) output**
- **Event time tag (ETT) time stamp with 100 ns resolution**

DESCRIPTION

The MGTR-II is a small, lightweight, field portable, GPS satellite receiver system specifically designed to perform end-to-end tests of line protection schemes, with Megger SMRT, MPRT and PULSAR relay test systems. The MGTR-II provides a precise programmed output pulse (POP), with 100 nanoseconds of resolution. This output pulse provides a trigger synchronization of two or more SMRT, MPRT or PULSAR test systems to less than $\pm 1 \mu$ Sec of the Universal Time Coordinated (UTC).

The MGTR-II consists of a twelve-channel GPS timing receiver integrated with proprietary microprocessor-controlled timing and interface logic. The MGTR-II simultaneously tracks all available GPS satellites. The microprocessor-controlled timing and interface logic derives precise timing information. In addition, the MGTR-II provides a standard 1 Pulse Per Second (PPS), and ASCII serial time message, external event time-tag, an IRIG-B serial time code output signal and most importantly, a programmable output pulse for performing end-to-end tests.

The unit comes with a 50 foot (15.2 m) long cable and all-weather, high-performance, high noise immunity antenna with an integrated low-noise preamplifier. The antenna comes with a 4 inch tall antenna mount.

Control of the MGTR-II is through a standard RS-232 serial connection. Software is provided to communicate to, and control the MGTR-II unit.

APPLICATIONS

Once energized, and after a period of time tracking GPS satellites, the accuracy of this unit approaches the accuracy of the Cesium clocks in the GPS satellites. This insures the highest accuracy possible for triggering end-to-end tests, as well as other timing applications. In addition to the programmable output pulse for performing end-to-end tests, other outputs include 1 pulse-per-second, and IRIG-B for synchronizing analog outputs of two or more test sets which use an external IRIG-B protocol or 1PPS signal. Other applications include using the IRIG-B time protocol for testing phasor measurement units (PMU), or time stamping the publishing of IEC 61850 sample values.

Two of the most advanced characteristics of the MGTR-II unit are the Intelligent Holdover™ and FastStart™ features. The Intelligent Holdover feature provides near-Rubidium holdover characteristics in the absence of GPS signals. This can be especially useful when performing end-to-end tests near government facilities, urban canyons, or mountainous regions, which may locally block GPS signals from time to time. This allows high accuracy triggering even when not receiving GPS timing signals. Under normal operating conditions, the FastStart feature brings the MGTR-II unit to high precision timing and stability within just minutes of applying power.

Typical test equipment set up for end-to-end tests is shown in the following figure. The test system shown consists of a SMRT relay test set, an MGTR-II satellite receiver and a personal computer to control the SMRT and MGTR-II units. A typical notebook computer will have a variety of communication ports. Shown in the figure below, the USB to RS-232 port is being used to control the programmable output pulse of the MGTR-II satellite receiver.

The three phase voltage and current outputs from the SMRT are connected to the relay under test. The breaker sensing inputs of the relay are connected to the binary output terminals of the SMRT, which will serve to simulate the circuit breaker. The relay trip contacts are connected to the binary input terminals of the SMRT. The MGTR-II units at the opposing terminals, with programmable trigger outputs, are programmed to trigger the SMRT test sets less than 1 microsecond of the UTC. This provides the synchronized outputs of multiple relay test sets at terminals that can be a hundred miles apart.

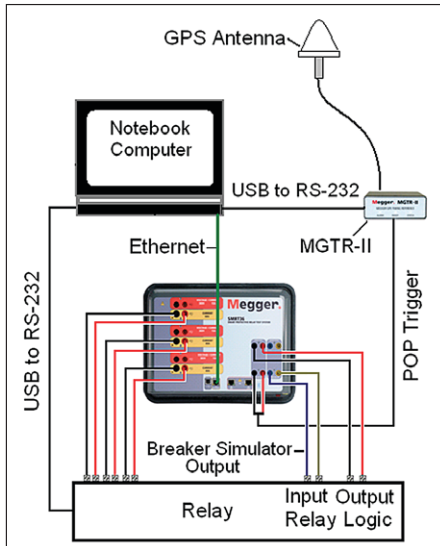

Typical end-to-end test setup

FEATURES AND BENEFITS

- **Programmable Output Pulse (POP)** - Used to trigger the end-to-end tests using Megger PULSAR, MPRT, or SMRT relay test sets. The POP can be specified by date, time, repetition (single pulse, or multiples), pulse polarity, and pulse width with 100 nanoseconds of resolution.
- **External Event Time Tag (ETT)** - Used to mark date and time of an external event with 100 nanoseconds of resolution. Multiple events are buffered, and the control software allows events to be archived.
- **State-of-the-art 12 channel GPS technology** - Capable of tracking up to 12 satellites simultaneously.
- **Intelligent Holdover™** - provides near-Rubidium holdover characteristics in the absence of GPS signals. This allows high accuracy triggering even when not receiving GPS timing signals. This provides end-to-end test capability in high foliage, mountainous, urban canyon environments and near government facilities where GPS signals may be temporarily blocked.
- **FastStart™** - Offers high accuracy within minutes of start-up, which provides faster time to first test.
- **IRIG-B Output** - Provides precise time outputs in the industry standard IRIG-B format. Used for synchronizing outputs for end-to-end tests, provides time stamping for IEC 61850 sampled values, or for testing phasor measurement units (PMU).
- **GPS Disciplined Ovenized Crystal Oscillator** - insures the highest accuracy possible for triggering end-to-end tests.

- **Windows® Based Control /Software** - Provides simple user interface to set the Programmable Output Pulse for end-to-end tests.
- **100 nanosecond Accuracy** - Insures the highest available accuracy for synchronized end-to-end tests.
- **RS-232 serial port** - The RS-232 port provides a computer interface to perform automatic testing.
- **Immediate error indication** - Visual alarm indicates when unit cannot supply corrected precise time due to loss of GPS signals.

SPECIFICATIONS

Input Power

AC/DC Adapter

100 to 240 VAC, 50/60 Hz to 24 VDC, 400mA, with 4-plug kit

Disciplined Oscillator

High performance ovenized crystal oscillator (OCXO), GBS controlled

Long-Term Accuracy

1 x 10⁻¹² after 24 hours tracking

Stability While Coasting

7 x 10⁻¹⁰ s/s

Receiver Type

12 parallel channel, code + carrier tracking, CA mode, L1 carrier

Time to First Fix (typical)

Hot Start:

<30 seconds (with valid almanac, time, date, position & ephemeris)

Warm Start:

<60 seconds (with valid almanac, time, date & position)

Cold Start:

<3 minutes typical, 12.5 minutes max (with no almanac, time, date or position)

Position Update Rate: Once per second, nominal

IRIG-B (Output A)

Data formats: B007 and B002

Drive: TTL into 50Ω

1 PPS (Output B)

(Referenced to UTC)

Drive: TTL into 50Ω

Rise Time: 10 ns Maximum

Pulse Width: Positive pulse, 1 ms nominal, rising edge on-time

Accuracy: 100 ns RMS

Programmable Output Pulse (Output C)

Drive: TTL into 50Ω

Rise/Fall Time: 10 ns Maximum

Pulse Width: Programmable from 1 μs - 250 ms

Polarity: Selectable, positive/negative

Resolution: 100 ns

Accuracy: 100 ns RMS

External Event Input (ETT)

TTL/CMOS level, edge-triggered, polarity selectable

Resolution: 100 ns

Accuracy: 100 ns RMS

Temperature Range (MGTR-II)

Operating: 14 to 158° F (-20 to 70° C)

Storage: -6 to 185° F (-40 to 85° C)

Relative Humidity (MGTR-II): 95% RH, Non-condensing

Temperature Range (GPS Antenna)

Operating /Storage: -11.2 to 158° F (-45 to 85° C)

Relative Humidity (Antenna): Water-proof/all weather

Dimensions

MGTR-II Unit Enclosure

4.125 W x 1.5 H x 4.0 D in.

104.8 W x 38.1 H x 101.6 D mm

MGTR-II Unit Weight

.85 lbs. (0.383 kg)

GPS Antenna Enclosure

5.0 H x 3.54 Diameter (in.)

38.1 H x 90.0 Diameter (mm)

GPS Antenna Weight

0.66 lbs (0.30 kg)

Safety

IEC 61010-1, Amendments 1 and 2

Enclosure

The unit comes mounted in a rugged enclosure for field portability. An optional padded soft-sided carry case is available. The soft-sided carry case protects the unit from light rain and dust. The soft case also has pockets to hold the antenna, cables and AC/DC power supply.

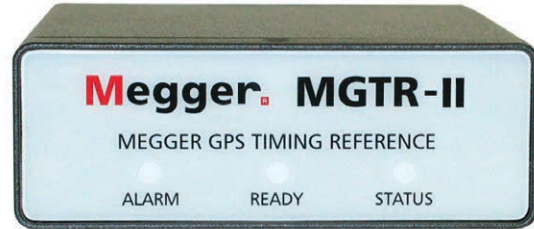

MGTR-II unit Front View



MGTR-II unit Rear View

ORDERING INFORMATION	
Item (Qty)	Cat. No.
Megger GPS Timing Reference Model MGTR-II, with 50 Ft. Cable	MGTR-II-50
Megger GPS Timing Reference Model MGTR-II, with 100 Ft. Cable	MGTR-II-100
Model MGTR-II Includes	
Instruction Manual and MGTR Control Software CD (1 ea)	83289
Coax Cable, M/M BNC, 3 ft (90 cm) (1 ea.)	620121
BNC to Banana Test Lead Adapter (1 ea.)	90003-671
AC/DC Power Adapter (1 ea.)	561024
GPS Antenna Kit with 50 ft (15.15 m) Cable (1 ea.)	90007-421
GPS Antenna Kit with 100 ft (30.3 m) Cable (1 ea.)	90007-407
Antenna Kit contains the following:	
GPS Antenna (1 ea.)	650016
4 inch SS Antenna Mount (1 ea.)	650017
50 ft. (15.15 m) Cable with TNC to SMA Connectors (1 ea.)	90007-422
100 ft. (30.3 m) Cable with TNC to SMA Connectors (1 ea.)	90007-423
Optional Accessory	
Soft-sided transit case (1 ea.)	MC6674

UK
Archcliffe Road, Dover
CT17 9EN England
T (0) 1 304 502101
F (0) 1 304 207342

UNITED STATES
4271 Bronze Way
Dallas, TX 75237-1019 USA
T 1 800 723 2861
T 1 214 333 3201
F 1 214 331 7399

OTHER TECHNICAL SALES OFFICES
Norristown USA, Toronto
CANADA, Mumbai INDIA,
Le Raincy FRANCE, Cherrybrook
AUSTRALIA, Guadalajara SPAIN
and The Kingdom of BAHRAIN.

ISO STATEMENT
Registered to ISO 9001:1994 Reg no. Q 09250
Registered to ISO 14001 Reg no. EMS 61597
MGTR-II_DS_EN_V01
www.megger.com
Megger is a registered trademark