

Megger[®]



AVO[®]830 and AVO[®]835

True RMS Digital Multi-Meter

User Guide

This document is copyright of:

Megger Limited, Archcliffe Road, Dover, Kent CT17 9EN. ENGLAND
T +44 (0)1304 502101 F +44 (0)1304 207342 www.megger.com

Megger Limited reserves the right to alter the specification of its products from time to time without notice. Although every effort is made to ensure the accuracy of the information contained within this document it is not warranted or represented by Megger Limited to be a complete and up-to-date description.

For Patent information about this instrument refer to the following web site:

megger.com/patents

This manual supersedes all previous issues of this manual. Please ensure that you are using the most recent issue of this document. Destroy any copies that are of an older issue.

Declaration of Conformity

Hereby, Megger Instruments Limited declares that radio equipment manufactured by Megger Instruments Limited described in this user guide is in compliance with Directive 2014/53/EU. Other equipment manufactured by Megger Instruments Limited described in this user guide is in compliance with Directives 2014/30/EU and 2014/35/EU where they apply.

The full text of Megger Instruments EU declarations of conformity are available at the following internet address:

megger.com/eu-dofc

Contents

1. Overview	6
1.1. Contact Megger UK	6
2. Safety	7
2.1. Safety Information	7
2.2. Measurement Connection	8
2.2.1. Voltage	8
2.2.2. CAT IV	8
2.2.3. CAT III	8
2.2.4. CAT II	8
2.3. Warnings, Cautions and Notes	8
2.3.1. Warnings	8
2.3.2. Cautions	8
2.3.3. Notes	8
2.4. Safety and Hazard Symbols	9
3. Introduction	10
3.4.1. Measurement Functions	10
4. Product Features	11
4.1. Overview	11
4.2. Function Buttons	12
4.3. Function Dial	13
4.4. Terminals	14
4.5. Display	15
5. Start-up Overview	16
5.1. Start-up and Shut-down	16
5.2. Auto Power Off (APO)	16
5.3. Battery Status	16
5.4. Range Selection	16
5.5. Backlight	16
6. Measurements	17
6.1. Non Contact Detection	17
6.2. Voltage Measurement	18
6.2.1. AC+DC Description	19
6.3. Phase Rotation / Sequence Detection	19
6.4. Resistance Measurement	20
6.4.1. Resistance Measurement Tips	21
6.5. Continuity Test	22
6.6. Conductance Measurement	23
6.7. Capacitance Measurement	24
6.7.1. Smart Capacitance	25
6.8. Diode Test	26

6.9. Frequency Measurement.....	28
6.10. Temperature Measurement	29
6.11. AC Voltage Detection.....	30
6.12. Current Measurement.....	31
6.12.1. Ampere Measurement.....	31
6.12.2. Milliampere Measurement.....	33
7. Maintenance	35
7.1. Batteries.....	35
7.1.1. Battery Status.....	35
7.2. Battery Replacement	35
7.3. Fuse Replacement.....	36
7.4. Clean the instrument	37
7.5. Technical Support	37
8. End of Life Disposal.....	38
8.1. WEEE Directive	38
8.2. Battery Disposal.....	38
9. Accessories.....	39
9.1. Optional and Replacement Accessories	39
10. Specifications.....	40
10.1. General Specifications.....	40
10.2. Technical Specifications.....	41
11. Repair and Warranty.....	43
11.1. Calibration, Service and Spare Parts.....	43
 Figures	
12. Fig 1: Voltage Measurement Set-up.....	18
13. Fig 2: Phase Rotation / Sequence Detection Set-up.....	19
14. Fig 3: Resistance Measurement Set-up	20
15. Fig 4: Continuity Test Set-up.....	22
16. Fig 5: Conductance Measurement Set-up	23
17. Fig 6: Capacitance Measurement Set-up.....	24
18. Fig 7: Diode Test Set-up.....	26
19. Fig 8: Forward Voltage Drop Across Semi-conductor Junction	27
20. Fig 9: Frequency Measurement Set-up.....	28
21. Fig 10: Temperature Measurement Set-up.....	29
22. Fig 11: AC voltage Detection Set-up	30
23. Fig 12: ≤ 10 A Measurement Set-up	31
24. Fig 13: ≤ 100 mA Measurement Set-up.....	33
25. Fig 14: Battery Replacement.....	35
26. Fig 15: Fuse Replacement.....	36

1. Overview

Thank you for purchasing an AVO® digital multi-meter from Megger®. This User Guide details the specifications, functional aspects and how to use the Megger digital multi-meter model No. AVO8 Series.

For your own safety and to get the maximum benefit from this Megger instrument, read and understand the safety warnings and instructions before the instrument is used.

Megger reserves the right to improve the content of this User Guide from time to time without notice.

Megger reserves and retains the intellectual property rights of the content including the design, text, graphics, and logos in this User Guide. Any partial or complete reproduction or usage of the content is strictly prohibited.

For the latest version of this User Guide visit: **www.megger.com**

To register this instrument go to: **uk.megger.com/register**

1.0.1 Contact Megger UK

Megger Ltd.

Archcliffe Road

Dover

CT17 9EN

UK

Tel: +44 (0) 1304 502101

Email: **uksales@megger.com**

Web: **www.megger.com**

2. Safety

2.1 Safety Information

Retain these safety warnings for future reference.

Read and understand the safety information before using the instrument.

The following warnings must be obeyed.

Important: This instrument must be used only by suitably trained and competent persons.

Users of this instrument and their employers must do a valid risk assessment of all electrical work to identify potential sources of electrical danger and risk of electrical injury, and must conform to national safety legislation. Where assessment shows significant risk from high energy systems, the use of fused leads must be considered.

- If the instrument is used in a manner not specified by the manufacturer, the protection provided by the instrument may be impaired.
- The instrument must not be used if any part of it is damaged.
- Use only Megger approved test leads and accessories with this instrument.
- Test leads and probes must be in good order, clean and have no broken or cracked insulation.
- Hold the test probes behind the finger-guards when they are in contact.
- Always check that the correct instrument connections and range selection have been made before connection to the test subject.
- Voltage or current that exceeds the instrument ratings can damage the instrument and present a shock or fire hazard.
- Use caution when working with voltages above 30 V AC rms, 42 V AC peak or 60 V DC. These voltages present a shock hazard.
- To avoid the risk of electric shock do not connect the thermocouple to circuits greater than 10 V.
- Before any resistance, continuity, diode, or capacitance measurements are started, circuits must be de-energised and isolated from the mains power.
- Before and after use always test a known voltage to check for correct instrument operation. Do not use the instrument if incorrect results are obtained.
- Make sure that the test probes are disconnected before the case or battery cover is opened.
- Replacement fuses must be of the correct type and rating.
- The instrument must not be used in wet conditions. If it should become wet, it must be dried thoroughly before use.
- Test leads, which are used for mains measurements, must be rated as appropriate for measurement category IV or III. They must also have a voltage rating of at least the voltage of the circuit to be measured.

2.2 Measurement Connection

Only Megger supplied test leads designed for this instrument provide the full safety rating.

2.2.1 Voltage

The rated measurement connection voltage is the maximum line to earth voltage at which it is safe to connect.

2.2.2 CAT IV

Measurement category IV: Equipment connected between the origin of the low-voltage mains supply and the distribution panel.

2.2.3 CAT III

Measurement category III: Equipment connected between the distribution panel and the electrical outlets.

2.2.4 CAT II

Measurement category II: Equipment connected between the electrical outlets and the user's equipment.

- Measurement equipment may be safely connected to circuits at the marked rating or lower. The connection rating is that of the lowest rated component in the measurement circuit.

2.3 Warnings, Cautions and Notes

2.3.1 Warnings

A Warning alerts the reader to situations where a hazard to personnel can occur. They are placed before the event to which they relate and are repeated at each applicable occasion.

2.3.2 Cautions

A Caution alerts the reader to situations where equipment damage may result if a process is not followed. They are placed before the event to which they relate and are repeated at each applicable occasion.



2.3.3 Notes

Notes give additional information that aid the reader in the use or understanding of the equipment or subject, they are not used when a Warning or Caution is applicable.

They are not safety related and may be placed either before or after the associated text as required.

2.4 Safety and Hazard Symbols

The Safety and Hazard symbols detailed in this section are marked on the instrument:

	Warning: High Voltage, risk of electric shock
	Caution: Refer to the User Guide
	AC (Alternating Current or Voltage)
	DC (Direct Current or Voltage)
OL	Overload
	Fuse
	Equipment complies with current 'C tick' requirements.
	EU conformity. Equipment complies with current EU directives.
	UK conformity. This equipment complies with current UK legislation
	Do not dispose of to landfill, sewage systems or by fire.
	Reference earth connection. Not a protective earth terminal

3. Introduction

The Megger Digital Meters AVO830 and AVO835 are battery powered true-RMS Multi-meters with a 10000 count dual display digital display and analogue arc. They are compact and easy to operate measurement instruments for electrical and electronic applications.

These instruments meet the CAT III and CAT IV safety standards.

New instruments are covered by a three year warranty from the date of purchase by the user, the second and third years are conditional on free product registration (see **11. Repair and Warranty (page 44)**).

- AVO830
 - Measures up to 600 V AC / DC
 - Category rating: CATIV 600 V
- AVO835
 - Measures up to 1000 V AC/DC
 - Temperature measurement
 - Category rating: CATIV 600 V
 - Category rating: CATIII 1000 V
- Equipment

Description	AVO830	AVO835
Test Lead Kit	■	■
Temperature Measurement Probe		■
AA Alkaline Battery	■	■
Quick Start Guide	■	■
Safety Warnings Sheet	■	■
Warranty information	■	■

3.4.1 Measurement Functions

This instrument measures and tests the following:

- **6.2 Voltage Measurement (page 18)**
- **6.3 Phase Rotation / Sequence Detection (page 19)**
- **6.4 Resistance Measurement (page 20)**
- **6.5 Continuity Test (page 22)**
- **6.6 Conductance Measurement (page 23)**
- **6.7 Capacitance Measurement (page 24)**
- **6.8 Diode Test (page 26)**
- **6.9 Frequency Measurement (page 28)**
- **6.10 Temperature Measurement (page 29)**
- **6.11 AC Voltage Detection (page 30)**
- **6.12 Current Measurement (page 31)**

4. Product Features

4.1 Overview

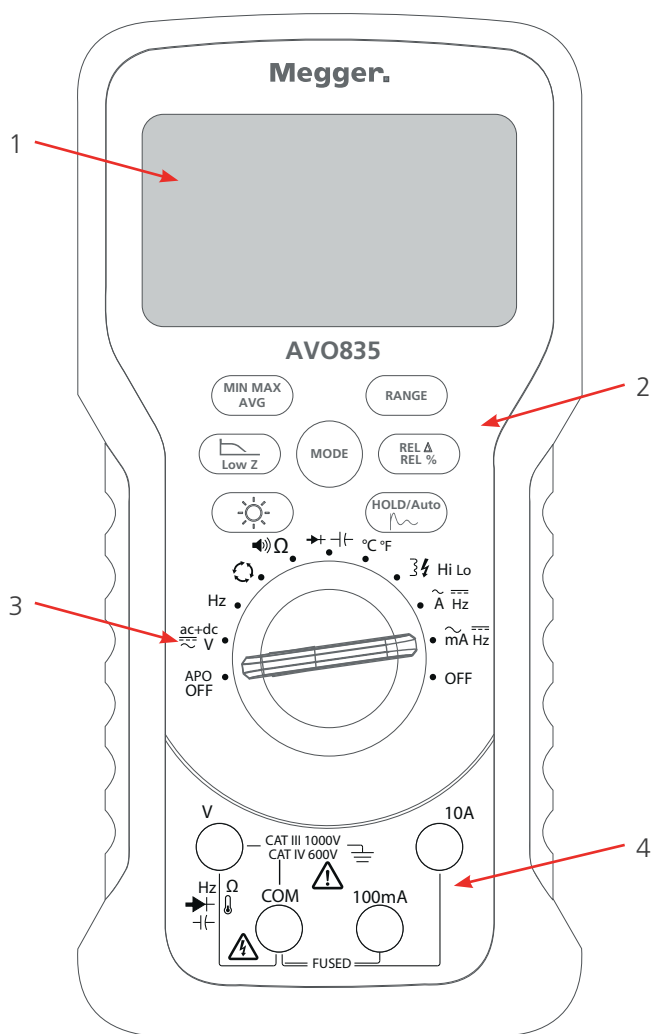

No.	Details
1	4.5 Display (page 15)
2	4.2 Function Buttons (page 12)
3	4.3 Function Dial (page 13)
4	4.4 Terminals (page 14)

4.2 Function Buttons

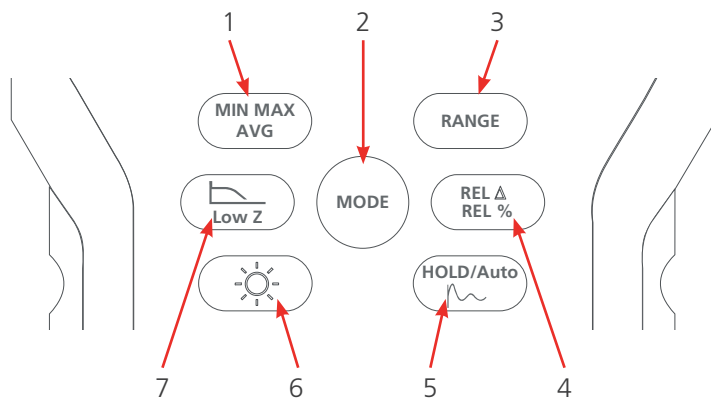

No.	Description	Available (Function Dial)
1	Record minimum, maximum or average values, shown on the Secondary display. Step through MIN, MAX and AVG readings Press and hold for two seconds to cancel	VAC, VDC AAC, ADC, Hz, Ω, Capacitor and Temperature measurement
2	Toggle through the available options at a selected function (see 4.3 Function Dial (page 13))	All positions
3	Select automatic or manual range (see 5.4 Range Selection (page 16))	VAC, VDC AAC, ADC, Hz, Ω and Capacitor measurement
4	REL Δ : Captures the current reading and shows it as a reference for subsequent readings on the Secondary display. The Primary display is the difference between the stored reading and subsequent readings REL % : Captures the current reading and shows it as a reference for subsequent readings on the Secondary display. The Primary display is a percentage of subsequent readings to stored reading Press and hold for two seconds to cancel	VAC, VDC AAC, ADC, Hz, Ω, Capacitor and Temperature measurement
5	HOLD : Capture the current reading and show the value on the Secondary display. The Primary display shows subsequent readings HOLD/Auto : Capture the current reading on the Secondary display. When a new stable reading is detected, the instrument beeps and shows the new reading Smooth : Measurements are refreshed every two seconds and shown on the Primary display Press and hold for two seconds to cancel	VAC, VDC AAC, ADC, Hz, Ω, Capacitor and Temperature measurement
6	Backlight : Set the backlight On / Off (automatically goes Off after one minute)	All positions
7	Low Z : Reduce the input impedance down to 10 KOhms during voltage and capacitance measurement In LPF (Low Pass Filter) mode the instrument continues to measure in the selected AC mode, but the signal diverts through a filter, which blocks unwanted voltages above 800 Hz	VAC, VDC, Capacitance

4.3 Function Dial

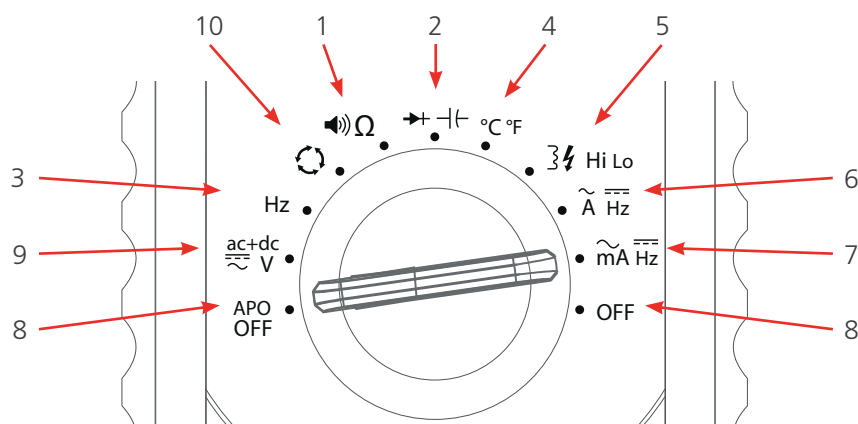

■ White symbols: Default function

■ Yellow symbols: Other functions

Press  repeatedly to select other functions.

No.	Function
1	6.4 Resistance Measurement (page 20) 6.5 Continuity Test (page 22) 6.6 Conductance Measurement (page 23)
2	6.7 Capacitance Measurement (page 24) 6.8 Diode Test (page 26). Measure the forward voltage drop across PN junction of diode and transistor
3	6.9 Frequency Measurement (page 28)
4	6.10 Temperature Measurement (page 29)
5	6.11 AC Voltage Detection (page 30) Detects live AC circuit in vicinity (Hi or Lo sensitivity)
6	6.12 Current Measurement (page 31) AC measurements 0.0 A to 10.00 A DC measurements 0.0 A to 10.00 A AC Frequency
7	Milliampere 6.12 Current Measurement (page 31) AC measurements 0.0 mA to 100.00 mA DC measurements 0.0 mA to 100.00 mA AC frequency
8	Instrument Off (battery power Off) APO is active by default (see Auto Power Off 5.5 Backlight (page 16))
9	6.2 Voltage Measurement (page 18) AC, DC, or AC+DC
10	6.3 Phase Rotation / Sequence Detection (page 19) Phase sequence detection of three phase AC supply

4.4 Terminals

For user safety it is important to:

- Always connect the common (COM) probe first and then connect the live probe to the circuit or the instrument
- Always remove the live probe first and then remove the common (COM) probe

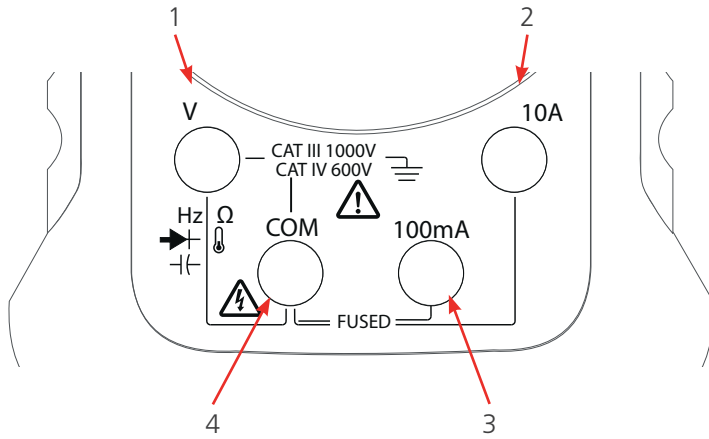

No.	Description	Details
1	V	Voltage, Resistance, Diode Capacitance and Voltage Frequency
2	10 A	≤ 10 A current measurements and frequency
3	100 mA	≤ 100 mA current measurements and frequency
4	COM	Return (Common)

4.5 Display

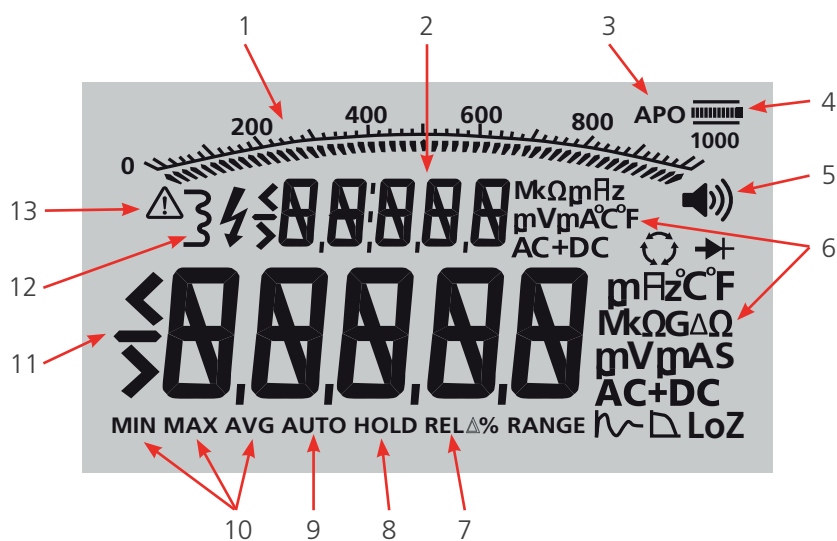

No.	Description
1	Analogue arc consist of linear scale and 53 needles
2	Secondary display
3	Auto Power Off (APO) active
4	Shows battery charge at 100%, 75%, 50% and 25%. Once the battery charge goes below 25%, the icon flashes to show that new batteries must be installed
5	Beep On
6	Primary and secondary display mode symbols
7	Relative function active
8	Hold active. If HOLD flashes, Auto Hold is active
9	Range: Auto shows when Auto range is selected.
10	Minimum, Maximum or Average modes
11	Primary display
12	Non-contact AC detection On.
13	Caution, hazardous condition

NOTE : Note: If **OL** shows on the display it means that the current reading is over range.

5. Start-up Overview

5.1 Start-up and Shut-down

- To start and use the instrument rotate the Function Dial to a function
- On start-up the instrument completes a self test routine before normal operation
- To shut-down rotate the Function Dial to **Off**

5.2 Auto Power Off (APO)

Auto Power Off (APO) is active by default. After 10 minutes of inactivity the instrument will go into a sleep mode.

To recover from sleep mode press any button or rotate the Function Dial to an adjacent function (the display for the selected function shows). All previously activated button features (MIN, MAX, AVG, HOLD, and so on) are discarded.

To Disabled APO

1. Press and hold .
2. Rotate the Function Dial to a function.

NOTE : Note: APO is also disabled in MIN, MAX and AVG mode.

5.3 Battery Status

When the battery icon flashes (25% battery life left) the batteries need to be replaced.



When **BAT LOW** shows on the display the instrument will not respond to user requests and will eventually shut-down. Replace the batteries.

See **To Replace the Batteries (page 35)**.

5.4 Range Selection

Select automatic or manual ranges (default: automatic). When set to automatic, the instrument automatically selects the range with best resolution.

To Set to Manual Range

1. Press and release , to toggle through the available ranges.
2. Press and hold  to return to AUTO range (**AUTO** shows on the display).

5.5 Backlight

Press  to set the backlight **On** or **Off**. The backlight automatically goes **Off** after one minute.

6. Measurements

This section details all the available measurements on the instrument.

For user safety it is important to:

- Always connect the common (COM) probe first and then connect the live probe to the circuit or the instrument.
- Always remove the live probe first and then remove the common (COM) probe.

6.1 Non Contact Detection

Measurement modes that are not designed to measure live circuits will sound a continuous audible beep and show **V OL** (flashing) on the display. Measurement is inhibited.

Test leads must immediately be disconnected from the circuit under test.

6.2 Voltage Measurement

The instrument features true RMS measurement, which gives accurate readings for distorted sine waves and other waveforms such as square waves, triangle waves, and staircase waves.

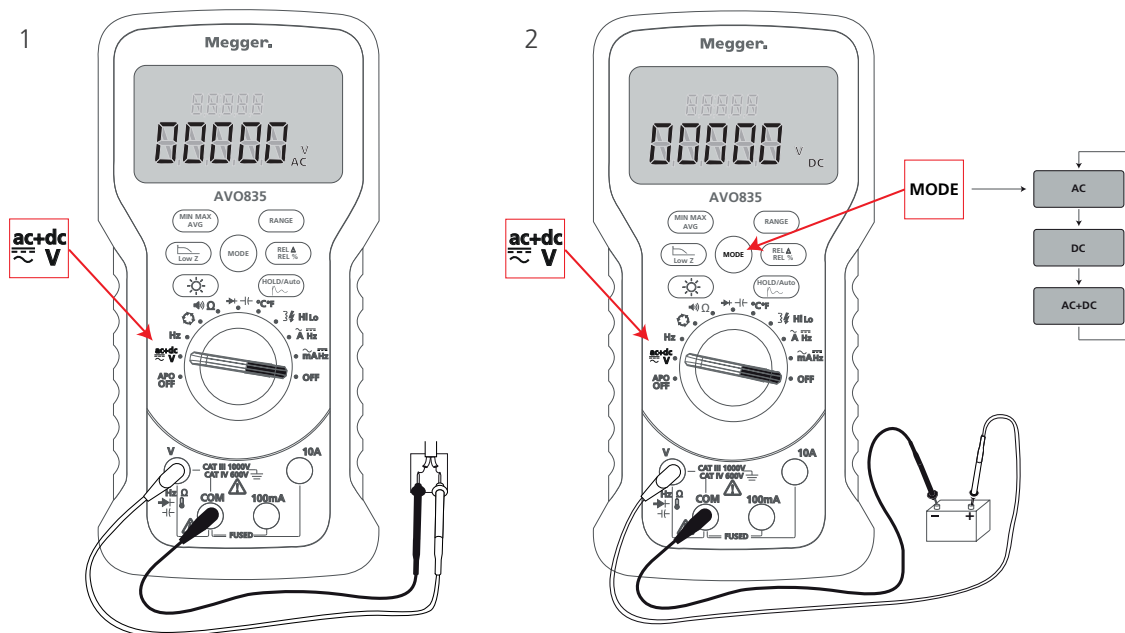

Fig 1: Voltage Measurement Set-up

No.	Description
1	AC voltage set-up
2	DC voltage set-up

To Measure Voltage

1. Set-up the instrument as shown in Fig 1.

- Set the Function Dial to ac+dc V
- Red test lead: V terminal
- Black test lead: COM terminal

2. Press **MODE** to toggle through:

- AC (default)
- DC
- AC + DC

3. If manual range is required, press **RANGE** repeatedly to scroll to a suitable range and resolution. Press and hold **RANGE** to return to AUTO range (AC and DC modes only).

Low Impedance Voltage Measurements: For AC Voltage measurements on cables with ghost voltage, press **Low Z** (low input impedance) mode. **LoZ** will show on the display.

6.2.1 AC+DC Description

The AC+DC function is used to measure complex voltages, which consist of both AC and DC components.

$$V_{AC+DC} = \sqrt{(V_{AC}^2 + V_{DC}^2)}$$

Therefore:

Where $V_{AC} = 230\text{ V}$ and $V_{DC} = 85\text{ V}$

Addition of AC and DC voltages give 315 V.

However:

$$\begin{aligned} V_{AC+DC} &= \sqrt{(V_{AC}^2 + V_{DC}^2)} \\ &= \sqrt{(230^2 + 85^2)} \\ &= \sqrt{(60125)} \\ &= 245.20\text{ V TRMS} \end{aligned}$$

6.3 Phase Rotation / Sequence Detection

Phase Rotation / Sequence Detection enables the connection of three phase power to the motor or any three phase appliance in correct sequence.

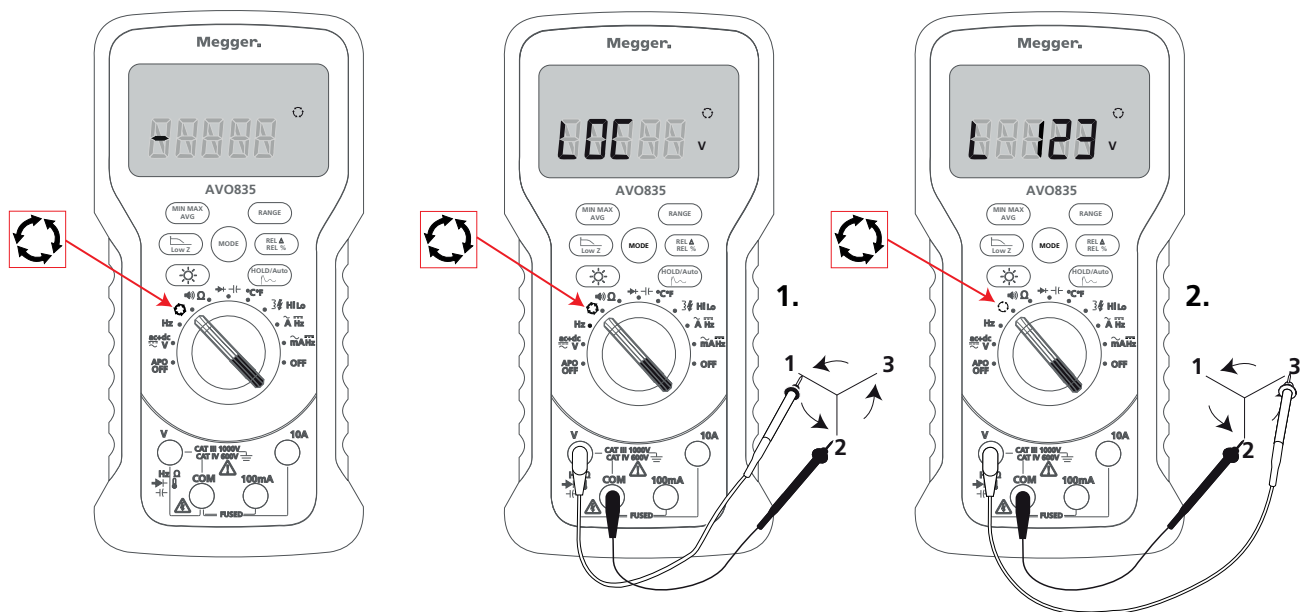



Fig 2: Phase Rotation / Sequence Detection Set-up

For a valid detection, set the voltage level and supply frequency to:

- ACV: > 80 V
- Supply Frequency: In the range 40 Hz to 80 Hz.

Measurements

To Detect Phase Rotation / Sequence

1. Set-up the instrument as shown in Fig 2.
 - Set the Function Dial to 
 - Red test lead: V terminal
 - Black test lead: COM terminal
2. The range locks to 1000 V and ---- shows on the Primary display.
3. Connect the V and COM probes to L1 and L2 phases of the three phase supply (1).
4. If the voltage and frequency are correct the instrument shows **LOC** on the Primary display.
5. Once **LOC** shows change L1 to third phase (L3) within eight seconds (2).
6. If phase changeover is not detected within eight seconds **t-OUT (Time Out)** shows on the Primary display.
7. If phase changeover is detected within eight seconds, the phase sequence result will show as:
 - L1 L2 L3 (phase sequence is OK / Forward), or
 - L3 L2 L1 (phase sequence is NOT OK / Reverse)
8. After three seconds test will start again on its own.

6.4 Resistance Measurement

To measure resistance a small current is sent through the circuit to be tested. Because this current flows through all possible paths between the test probes, the resistance reading represents the total resistance of all paths between the test probes. Therefore to measure the resistance of:

- A Resistor: Disconnect at least one connection (1)
- A Variable resistor: Disconnect at least two connections (2)

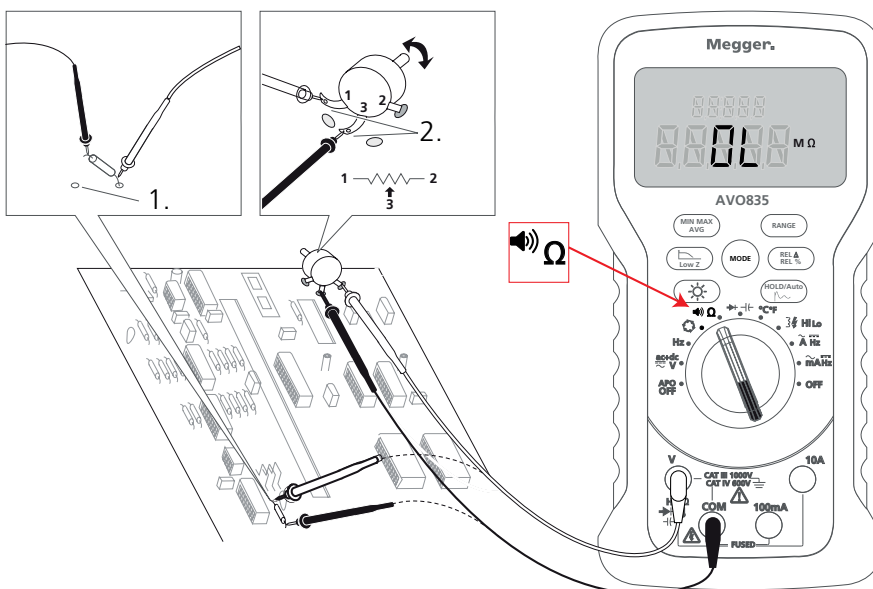

Fig 3: Resistance Measurement Set-up

CAUTION : Caution: To avoid possible damage to the instrument or to the equipment under test, make sure that the circuit power is disconnected and all high-voltage capacitors are discharged before resistance is measured.



To Measure Resistance

1. Make sure that:
 - The circuit power is disconnected
 - All high-voltage capacitors are discharged

NOTE : Note: If a live circuit is detected the instrument will sound a pulsed audible beep and **V OL** (flashing) shows on the display.



2. Set-up the instrument as shown in Fig 3.

- Set the Function Dial to  Ω
- Red test lead: V terminal
- Black test lead: COM terminal

3. If manual range is required, press  repeatedly to scroll to a suitable range and resolution. Press and hold  to return to AUTO range.
4. Connect the test probe tips to the circuit under test.

The display shows **OL** until a circuit is detected and shows the appropriate resistance when the circuit is detected.

6.4.1 Resistance Measurement Tips

- The measured value of a resistor in a circuit is often different from the actual value of the resistor
- Test probes can add 0.1 Ω to 0.2 Ω of error to resistance measurements. To test this resistance, touch the probe tips together and read the resistance of the test probes. If required, press  to automatically subtract this value
- The resistance function can produce enough voltage to forward-bias silicon diode or transistor junctions, causing them to conduct. If this is suspected, press  to apply a lower current in the next higher range

6.5 Continuity Test

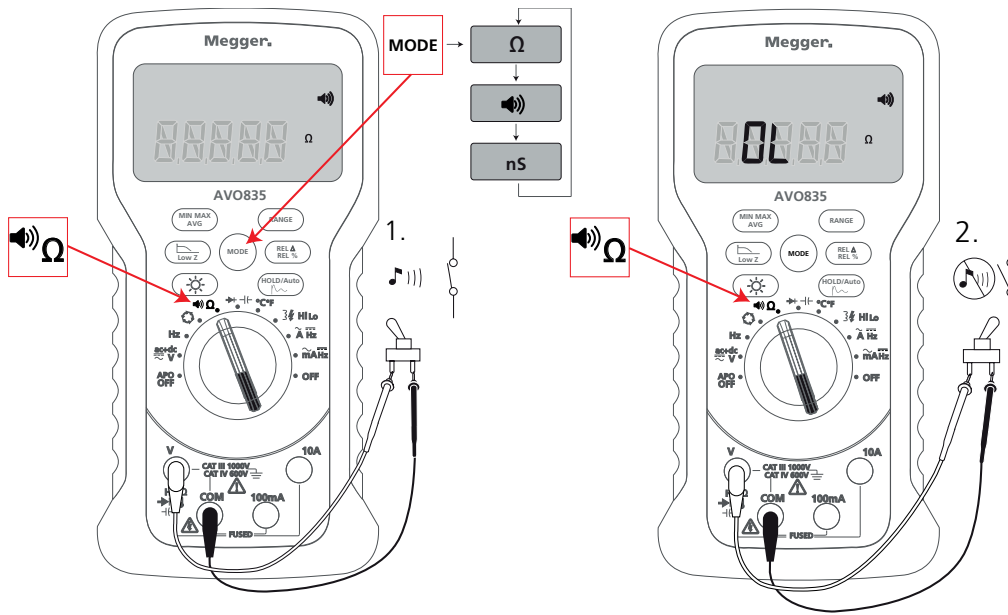

Fig 4: Continuity Test Set-up

No.	Description
1	Closed Circuit (audible beep)
2	Open circuit (no audible beep)

CAUTION : Caution: To avoid possible damage to the instrument or to the equipment under test, make sure that the circuit power is disconnected and all high-voltage capacitors are discharged before a continuity test.

To Detect Any Open or Short Circuits

- Make sure that:
 - The circuit power is disconnected
 - All high-voltage capacitors are discharged

NOTE : Note: If a live circuit is detected the instrument will sound a pulsed audible beep and **V OL** (flashing) shows on the display.

- Set-up the instrument as shown in Fig 4.

- Set the Function Dial to Ω .
- Red test lead: V terminal
- Black test lead: COM terminal
- Press to select

3. Connect the test probes to the cable or circuit under test.

The Primary display shows the resistance value and the instrument sounds an audible beep dependant on the resistance:

Resistance	Beep mode
$\leq 5 \Omega$	Continuous beep
$< 5 \Omega$ to $< 50 \Omega$	Intermittent beep
$\geq 50 \Omega$	No beep

The continuity function can detect intermittent open and short circuits, which last as little as 10 ms

6.6 Conductance Measurement

Conductance, the inverse of resistance, is the ability of a circuit to pass current. High values of conductance correspond to low values of resistance.

The instrument's 1 nS to 60 nS range measures conductance with resolution of 0.01 nS. Because such small amounts of conductance correspond to extremely high resistance, the nS range can determine the resistance of components up 1 G Ω .

A current flows through all possible paths between the test probes, the conductance reading represents the total conductance of all paths between the test probes. Therefore to measure the conductance of:

- A Resistor: Disconnect at least one connection (1)
- A Variable resistor: Disconnect at least two connections (2)

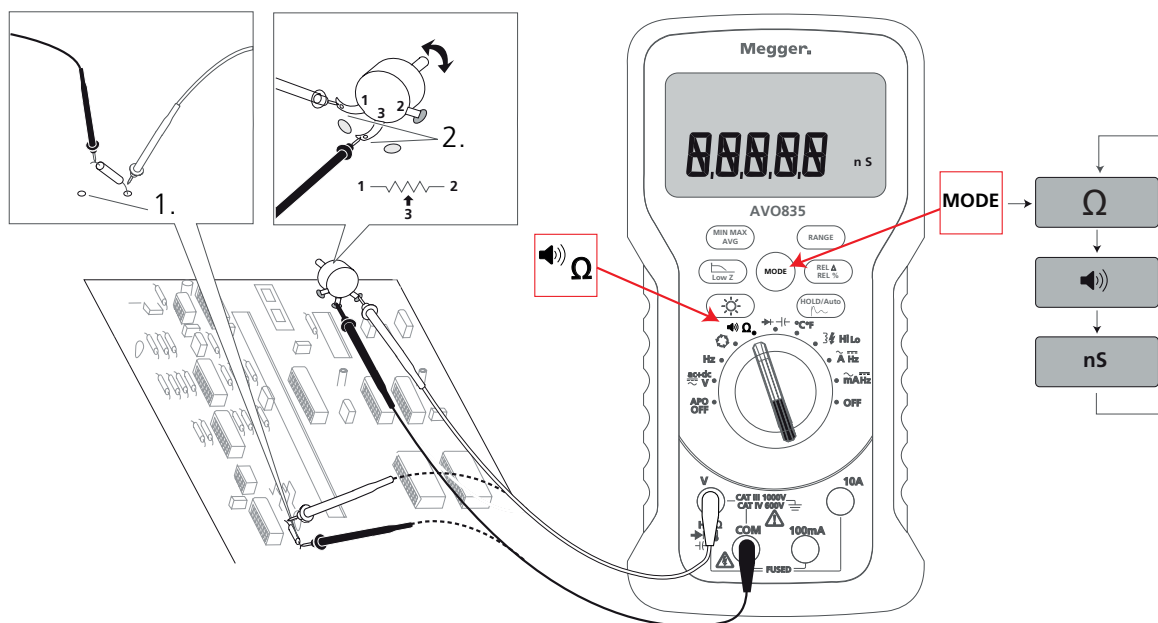

Fig 5: Conductance Measurement Set-up

Measurements

CAUTION : Caution: To avoid possible damage to the instrument or to the equipment under test, make sure that the circuit power is disconnected and all high-voltage capacitors are discharged before conductance is measured.

To Measure Conductance

1. Make sure that:
 - The circuit power is disconnected
 - All high-voltage capacitors are discharged

NOTE : Note: If a live circuit is detected the instrument will sound a pulsed audible beep and **V OL** (flashing) shows on the display.

2. Set-up the instrument as shown in Fig 5.
 - Set the Function Dial to Ω

- Press  twice to select **n S**
- Red test lead: V terminal
- Black test lead: COM terminal

3. Connect the test probe tips to the circuit under test.

The display shows **0.00 nS** until the circuit is detected and shows the appropriate conductance when the circuit is detected.

6.7 Capacitance Measurement

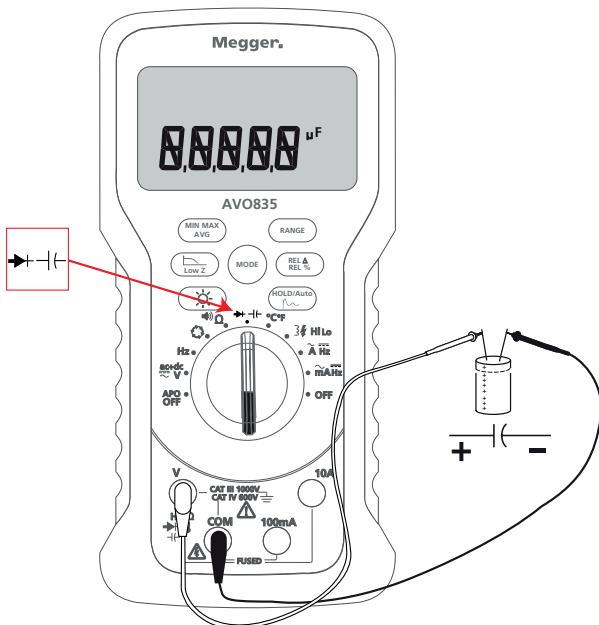

Fig 6: Capacitance Measurement Set-up

CAUTION : Caution: To avoid possible damage to the instrument or to the equipment under test, make sure that the circuit power is disconnected and all high-voltage capacitors are discharged before capacitance is measured. Use the DC voltage function to confirm that the capacitor is discharged.

To Measure Capacitance

1. Make sure that:
 - The circuit power is disconnected
 - All high-voltage capacitors are discharged

NOTE : Note: If a live circuit is detected the instrument will sound a pulsed audible beep and **V OL** (flashing) shows on the display.

2. Set-up the instrument as shown in Fig 6.

- Set the Function Dial to 
- Red test lead: V terminal
- Black test lead: COM terminal

Once the test probes are connected to the capacitor the capacitance is shown on the Primary display.

NOTE : Note: This can take a few seconds on large capacitance.

6.7.1 Smart Capacitance

Patent applied for.

When the test leads are connected to a capacitor, which has a residual charge, the live circuit is enabled.

The Smart Capacitance function monitors the charge status of the capacitor, when the charge status reaches a safe level the instrument will then do a capacitance measurement.

6.8 Diode Test

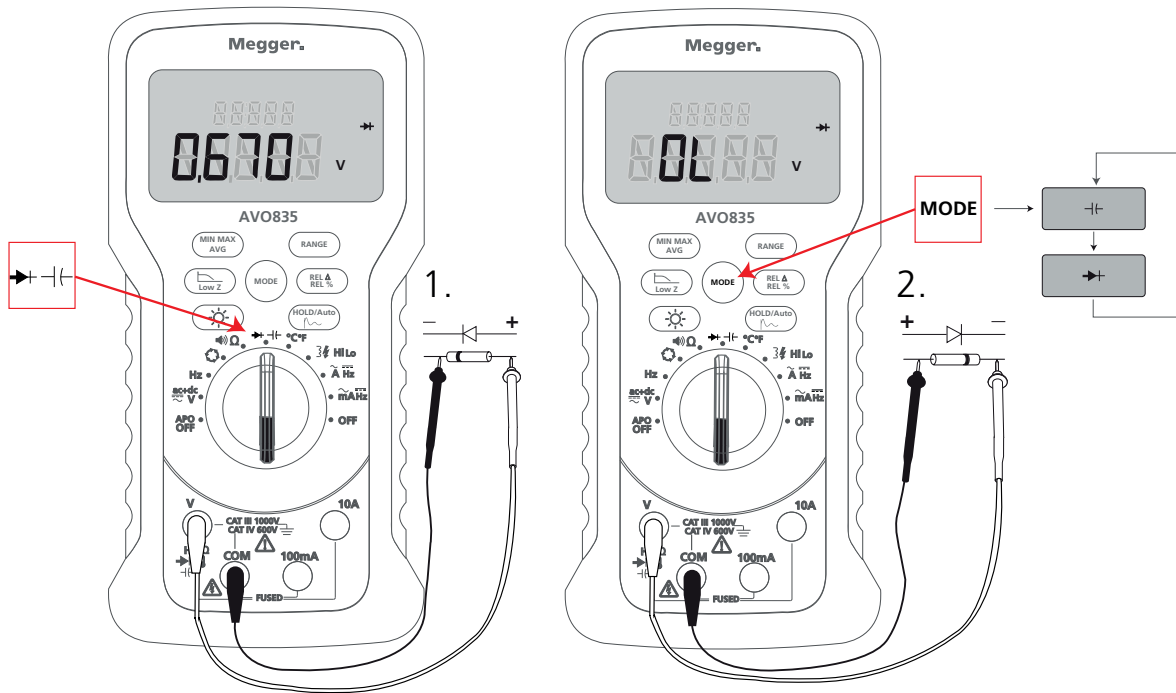

Fig 7: Diode Test Set-up

No.	Description
1	Forward Bias
2	Reverse Bias

CAUTION : Caution: To avoid possible damage to the instrument or to the equipment under test, make sure that the circuit power is disconnected and all high-voltage capacitors are discharged before diode tests are started.

To Test a Diode

- Make sure that:
 - The circuit power is disconnected
 - All high-voltage capacitors are discharged

NOTE : Note: If a live circuit is detected the instrument will sound a pulsed audible beep and **V OL** (flashing) shows on the display.

- Set-up the instrument as shown in Fig 7 for forward or reverse bias.

- Set the Function Dial to
- Press to select

3. Connect the test probe tips to the diode.

The Primary display shows the forward voltage drop (Fig 8).

- The display shows **OL** (out of range) if the diode is open (3 (fault open circuit)).
- If diode is short circuit an audible beep will sound (4 (fault short circuit))

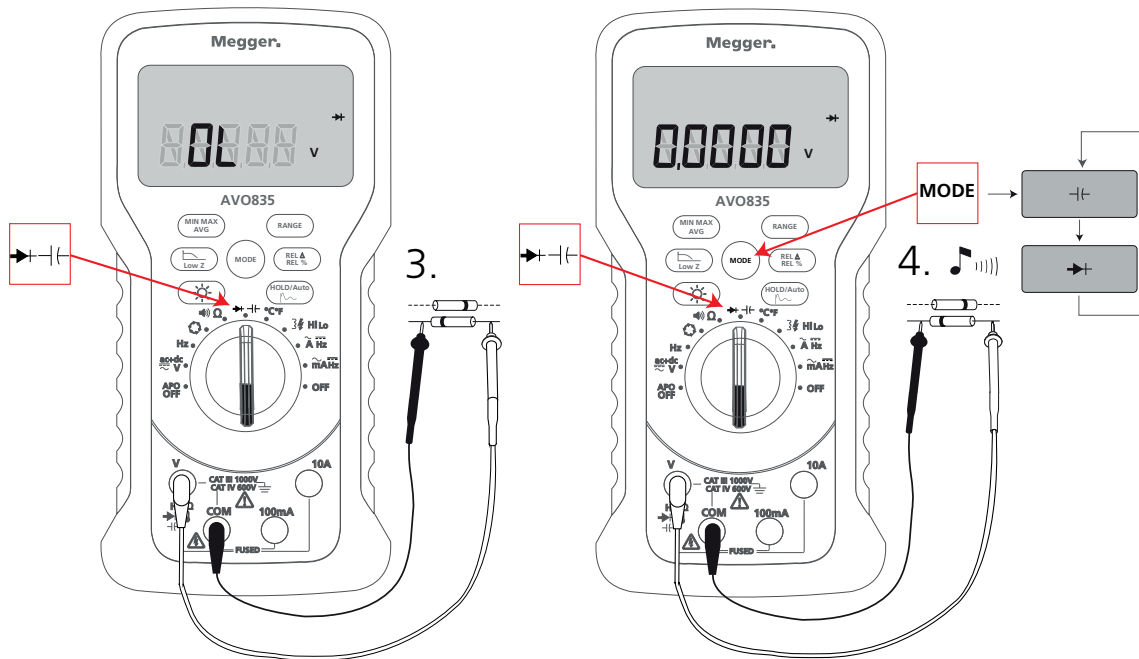

Fig 8: Forward Voltage Drop Across Semi-conductor Junction

6.9 Frequency Measurement

To measure the frequency of a voltage signal the instrument counts the number of times the signal crosses a threshold level each second.

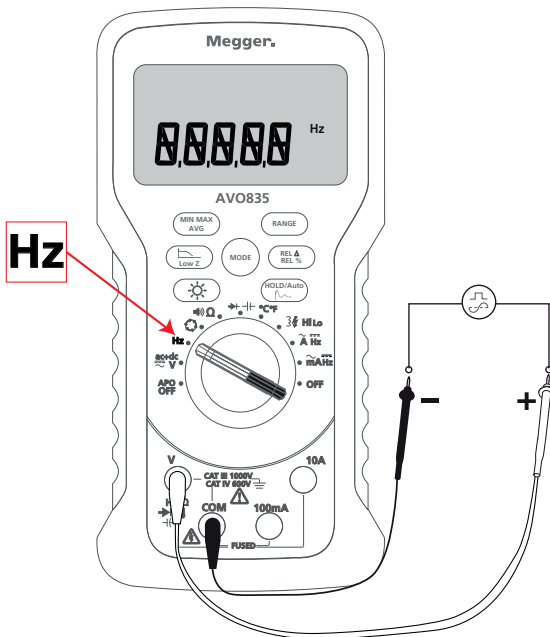

Fig 9: Frequency Measurement Set-up

To Measure Frequency

1. Set-up the instrument as shown in Fig 9.

- Set the Function Dial to **Hz**.
- Red test lead: V terminal
- Black test lead: COM terminal

2. Connect the test probe tips to the circuit under test.

The Primary display shows the frequency in Hz.

3. If manual range is required, press **RANGE** repeatedly to scroll to a suitable range and resolution. Press and hold **RANGE** to return to AUTO range.

6.10 Temperature Measurement

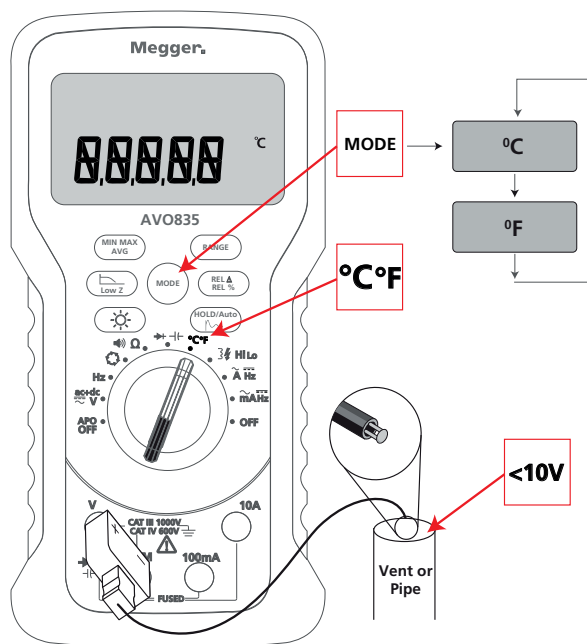

Fig 10: Temperature Measurement Set-up

To Measure Temperature

WARNING : ⚠️⚠️ Warning: To avoid the risk of electric shock do not connect the thermocouple to circuits greater than 10 V.

The instrument measures the temperature of a type-K thermocouple.

1. Set-up the instrument as shown in Fig 10.

- Set the Function Dial to $^{\circ}\text{C } ^{\circ}\text{F}$.
- Temperature Measurement Probe '+': V terminal
- Temperature Measurement Probe '-': COM terminal

Press  to toggle between $^{\circ}\text{C}$ or $^{\circ}\text{F}$.

OL shows on the Primary display if:

- The reading is out of range, or
- A sensor is disconnected or open circuit

6.11 AC Voltage Detection

To detect AC voltage, the top of the instrument must be placed close to a live conductor.

The instrument gives an audible, as well as a visual, indication when voltage is detected.

CAUTION : Caution: If there is no voltage indication, voltage could still be present. Do not rely on this detection when used in the vicinity of shielded wire. Operation may be effected by differences in socket design, insulation thickness and type.

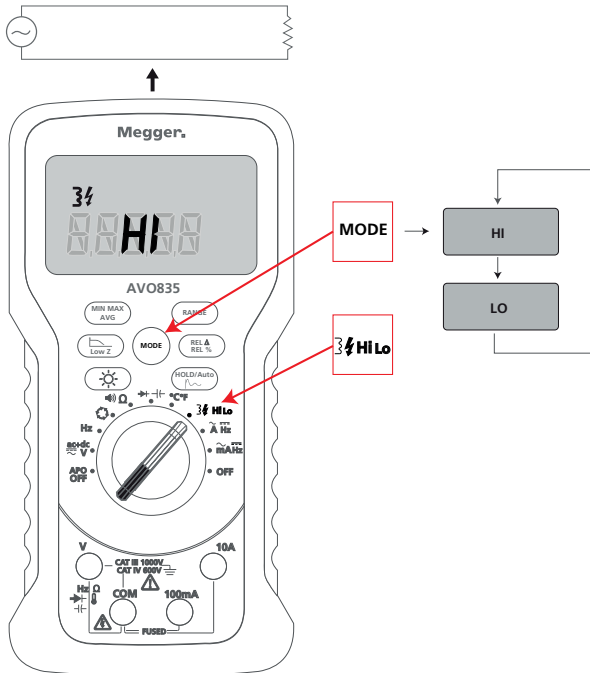

Fig 11: AC voltage Detection Set-up

There are two sensitivity settings:

To Check the Presence of AC Voltage

1. Set-up the instrument as shown in Fig 11.

- Set the Function Dial to .

2. Place the instrument close to a live conductor.

3. Press  to select:

- **HI:** (default) Highest sensitivity to AC voltage
- **LO:** Low sensitivity to AC voltage

6.12 Current Measurement

CAUTION : Caution: To avoid possible damage to the instrument or to the equipment under test:

- Check the instrument's fuses before a current is measured
- Use the correct terminals, function, and range for all measurements
- Never place the test probes across (in parallel with) any circuit or component when the test probes are plugged into the current terminals

NOTE : Note: To produce a positive reading connect the **black** test probe to the negative side of the circuit and connect the **red** test probe to the positive side of the circuit. If the test probes are reversed it will produce a negative reading, but will not damage the instrument.

AC current measurement is selected by default. Press MODE to toggle through AC or DC measurements.

6.12.1 Ampere Measurement

WARNING : Warning: To avoid possible electric shock or personal injury never attempt an in-circuit current measurement, where the open-circuit potential to earth is greater than 1000 V. You may damage the instrument or be injured if the fuse blows during such a measurement.

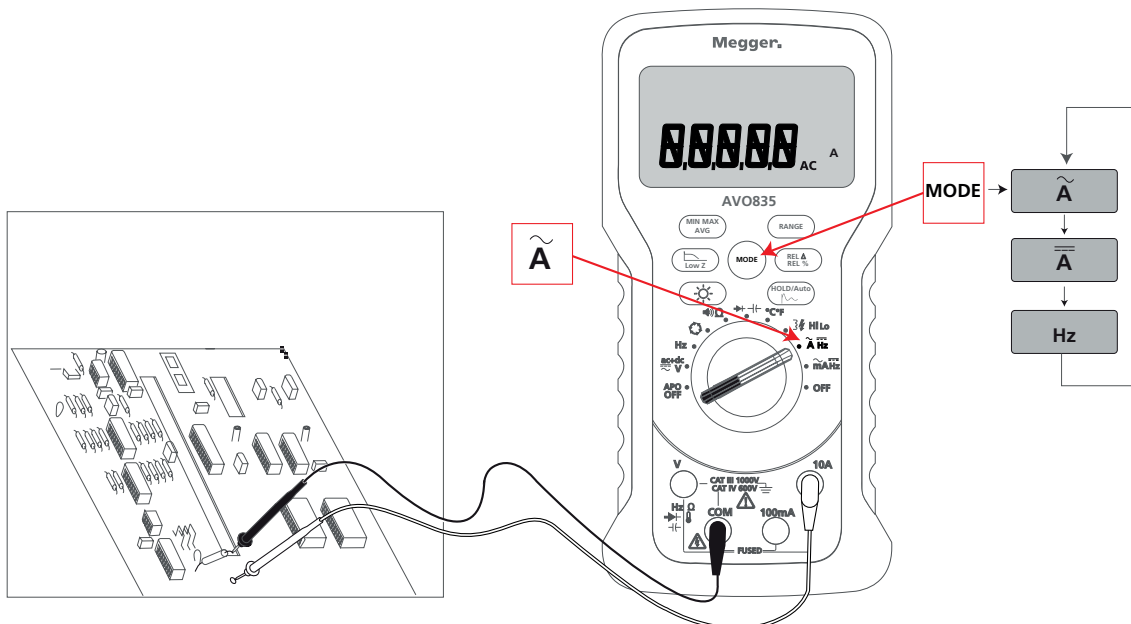





Fig 12: ≤ 10 A Measurement Set-up

6.12.2 To Measure AC or DC current ≤ 10 A

CAUTION : Caution: To avoid blowing the instrument's 100 mA fuse, use the mA terminal only if the current is continuously less than 100 mA.

1. Set-up the instrument as shown in Fig 12.

- Set the Function Dial to 
- Red test lead: 10 A terminal
- Black test lead: COM terminal

2. Press  to toggle AC (default) or DC measurement
3. Set the circuit power to **Off**.
4. Make sure that high voltage capacitors are discharged.
5. Connect the test leads in circuit
6. Set the circuit power to **On**.
7. If manual range is required, press  repeatedly to scroll to a suitable range and resolution. Press and hold  to return to AUTO range.
8. Once the reading is done, disconnect the supply before the test probes are removed.

6.12.3 Milliampere Measurement

WARNING : Warning: To avoid possible electric shock or personal injury never attempt an in-circuit current measurement, where the open-circuit potential to earth is greater than 1000 V. You may damage the instrument or be injured if the fuse blows during such a measurement.

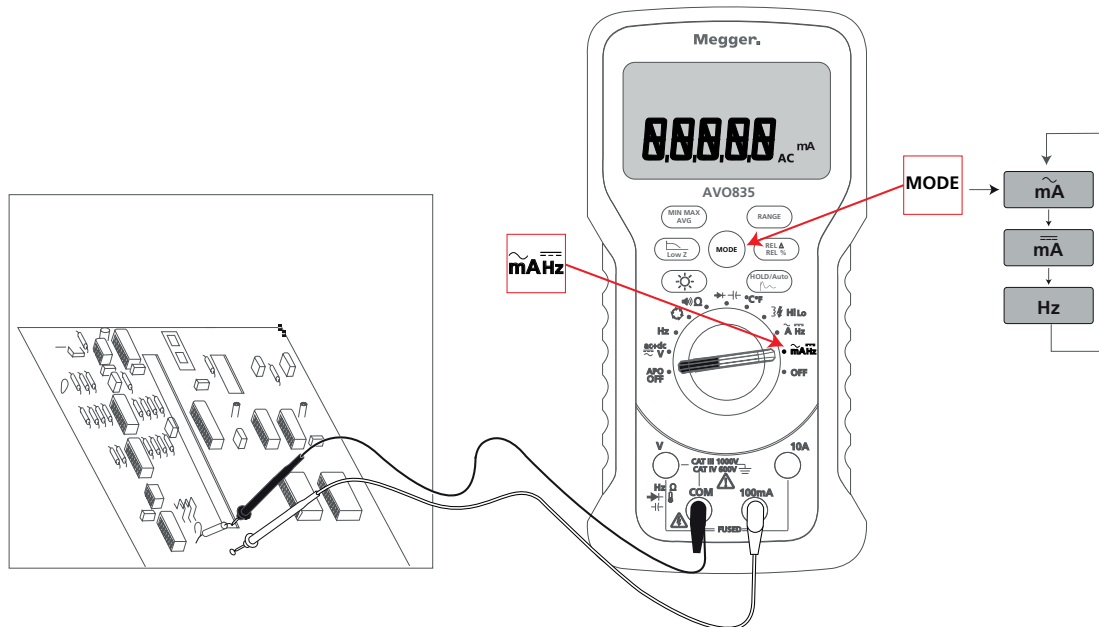



Fig 13: ≤ 100 mA Measurement Set-up

To Measure AC or DC current ≤ 100 mA

CAUTION : Caution: To avoid blowing the instrument's 100 mA fuse, use the mA terminal only if the current is continuously less than 100 mA.



1. Set-up the instrument as shown in Fig 13.

- Set the Function Dial to $\tilde{\text{mA}} \text{ Hz}$.
- Red test lead: 100 mA terminal
- Black test lead: COM terminal

2. Press  to toggle AC (default) or DC measurement
3. Set the circuit power to **Off**.
4. Make sure that high voltage capacitors are discharged.
5. Connect the test leads in circuit
6. Set the circuit power to **On**.
7. Once the reading is done, disconnect the supply before the test probes are removed.

Measurements

To Measure the Frequency of the Current from Amp and mA Input

1. Repeat the procedure for 10 A or 100 mA.
2. Press  to toggle through AC, DC and Hz.
3. Make sure that **Hz** is shown on the display.
4. Three ranges are available (100 Hz, 1 KHz and 10 KHz).
5. If manual range is required, press  repeatedly to scroll to a suitable range and resolution. Press and hold  to return to AUTO range.

7. Maintenance

For instrument calibration and calibration intervals, which includes any test equipment required, refer to instrument Service Manual.

These instruments contain no user repairable parts and if defective should be returned to your supplier in the original packaging or packed so that it is protected from damage during transit. Damage in transit is not covered by this warranty and replacement / repair is chargeable (see **11. Repair and Warranty (page 44)**)

7.1 Batteries

WARNING : Warning: To avoid false readings, which could lead to possible electric shock or personal injury, replace the batteries as soon as the battery indicator starts to flash.

CAUTION : Caution: Do not mix used batteries with general waste stream. Use a qualified recycler or hazardous material handler to dispose of used batteries.

CAUTION : Caution: Always set the instrument to Off and remove the test leads before the batteries are removed and installed. Only use approved batteries.

Approved batteries (see **10.1 General Specifications (page 40)**).

7.1.1 Battery Status

When the battery icon flashes (25% battery life left) the batteries need to be replaced.

When **LOW BAT** shows on the display the instrument will not respond to user requests and will eventually shut-down. Replace the batteries

7.2 Battery Replacement

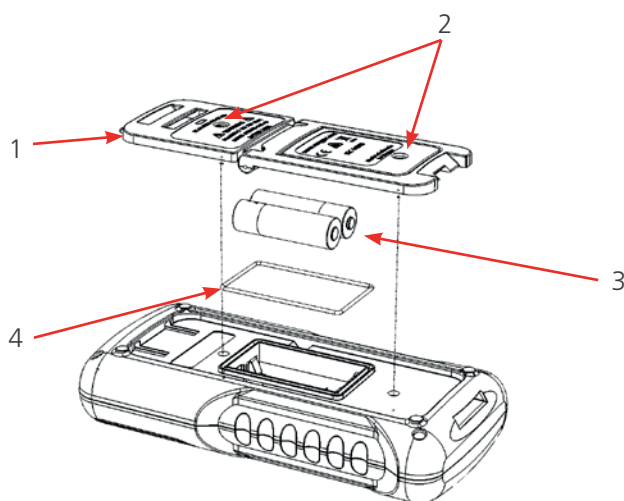

Fig 14: Battery Replacement

To Replace the Batteries

1. Set the Function Dial to **Off**.
2. Remove the test probes from the terminals.
3. Use a flat blade screwdriver to loosen the two captive screws (2). Remove the battery cover (1).
4. Replace the batteries (3).
5. Install the battery cover. Make sure that the gasket (4) is correctly seated. Tighten the two battery cover screws clockwise to secure.
6. Dispose of old batteries (see **8.2 Battery Disposal (page 38)**).

7.3 Fuse Replacement

CAUTION : Caution: To avoid personal injury or damage to the instrument, install only approved fuses (see 9. Accessories (page 39)).

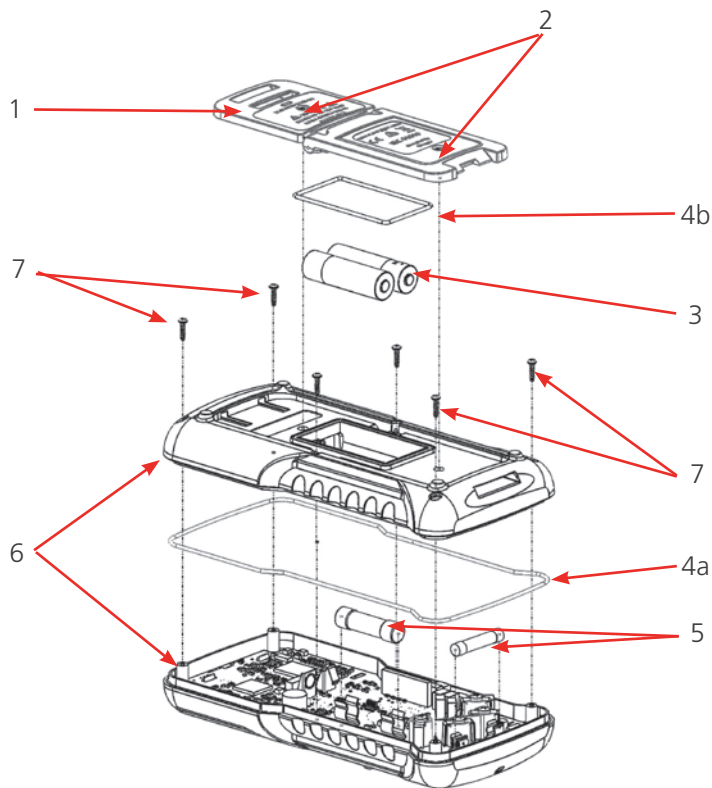

Fig 15: Fuse Replacement

To Replace Fuses

1. Set the Function Dial to **Off**.
2. Remove the test probes from the terminals.
3. Use a flat blade screwdriver to loosen the two captive screws. Remove the battery cover.
4. Remove the batteries.
5. Remove the 6 Phillips-head screws from the case bottom (7).
6. Part the two halves of the case (6).

NOTE : Tip: Gently push down on the battery terminal connected to the PCB from inside the battery compartment to help separate the two halves of the case.

7. Replace the fuse or fuses (5). Gently lever one end loose, and slide the fuse out of its clip.
8. Use specified replacement fuses only (see **9. Accessories (page 39)**).
9. Put the two case halves together. Make sure that the gasket (4a) is correctly seated and that the case halves snap together around the all edges.
10. Must use the 6 original screws provided by the manufacturer to secure the two case halves together. Do not over tighten. The screws provided by the manufacturer must be used.
11. Install the batteries.
12. Install the battery cover. Make sure that the gasket (4b) is correctly seated. Tighten the two battery cover captive screws to secure.

7.4 Clean the instrument

CAUTION : Caution: Do not use abrasives, isopropyl alcohol or solvents to clean the case or lens/window. These substances can damage the case materials.

- Cleaning interval: As required
- The instrument should be kept free of dust and liquids
- Dirt or moisture in the terminals can affect readings
- Wipe the case with a damp cloth and mild detergent

7.5 Technical Support

For technical support go to the Megger technical support site (uk.megger.com/support). See the exhaustive FAQs, technical support documents and information about After Sales support.

Alternatively:

- Call +44 (0) 1304 502101 (After Sales support), or
- Submit a completed After Sales Support form (see uk.megger.com/support/after-sales-support).

8. End of Life Disposal

8.1 WEEE Directive



Do not dispose of the product with normal waste at the end of its life.

Megger is registered in the UK as a Producer of Electrical and Electronic Equipment (Reg No.: WEE/HE0146QT).

For more information about the disposal of this product contact your local Megger company / distributor or go to your local Megger website.

8.2 Battery Disposal



Do not dispose of batteries with normal waste at the end of their life.

This product uses these types of batteries:

- AA size alkaline (LR6), or
- NiMH (HR6)

See **To Replace the Batteries (page 35)**, for location and how to safely replace the instrument batteries.

Dispose of batteries as per your local authority regulations.

Megger is registered in the UK as a Producer of Batteries (Reg No.: BPRN00142).

For more information go to **www.megger.com**.

9. Accessories

9.1 Optional and Replacement Accessories

Part Description		Quantity	Part Number
Battery	AA size alkaline (LR6)	2	1009-215
	NiMH (HR6)	2	1009-214
Fuse 11 A 1000 V 30 kA (10 mm x 38 mm)		1	1009-213
Fuse FF 0.125 mA 1000 V 30 kA (6.3 mm x 32 mm)		5	1009-212
Test Lead Kit (not fused)	x2 leads (black/red)	1	1002-001
	x2 crocodile clips (black/red)		
Test Lead Kit (500 mA)	x2 leads (black/red)	1	1002-015
	x2 long probes (black/red)		
Thermocouple Sensor (AVO835 only)		1	1010-461
Magnetic Hanger		1	1010-013

10. Specifications

This section covers general and technical specifications for this instrument.

10.1 General Specifications

The instrument complies with these standards:

- IEC/EN 61010-1
- IEC/EN 61010-2-033
- IEC/EN 61326-1

Item	Value
Maximum voltage between any terminal and ground (earth)	1000 Vrms (AVO835), 600 Vrms (AVO830)
Surge Protection	8 kV Peak (IEC/EN-61010-1)
Fuse protection for mA Input	FF 0.125 A, 30 kA @1000 V Fuse
Fuse protection for A Input	11 A, 30 kA @1000 V Fuse
Primary display	10000 counts
Secondary display	10000 counts
Analogue Arc	53 segments
Working Temperature	-10 °C to +50 °C (14 °F to 122 °F)
Storage Temperature	-30 °C to +70 °C (-22 °F to 158 °F)
Working Relative Humidity	≤ 90 % at 40 °C (104 °F)
Storage Relative Humidity	≤ 50 % at 60 °C (140 °F)
Altitude rating	2000 m (6561.5 ft)
Battery	x2 AA Alkaline (LR6) or x2 NiMH (HR6)
Battery life	150 hours (without backlight)
IP Rating (dust and water protection)	IP54 Category 2

10.2 Technical Specifications

For all detailed specifications, the accuracy is given as +/- ([% of reading] + [number of least significant digits]) at 18 °C to 28 °C (64°F to 82°F), with relative humidity up to 90 %, for a period of one year after calibration.

Voltage (DC)

Range	AVO830 - 1.0000 V, 10.000 V, 100.00 V, 600.0 V AVO835 - 1.0000 V, 10.000 V, 100.00 V, 1000.0 V
Accuracy	±0.1% +2
Input resistance	10 MΩ / 10 KΩ

Voltage (AC)

Range	AVO830 - 1.0000 V, 10.000 V, 100.00 V, 600.0 V AVO835 - 1.0000 V, 10.000 V, 100.00 V, 1000.0 V
Accuracy	45 Hz - 500 Hz ±1.0% +3 500 Hz - 1 kHz ±2.0% +3 1 kHz - 5 kHz ±3.0% +3
Input resistance	10 MΩ / 10 KΩ

Current measurement (DC)

Range	100.00 mA, 1.0000 A, 10.000 A
Accuracy	±1.0% +3

Current measurement (AC)

Range	100.00 mA, 1.0000 A, 10.000 A
Accuracy	45 Hz - 500 Hz ±1.5% +10 500 Hz - 1 kHz ±2.0% +20

Phase rotation

Range	95 V - 440 V
--------------	--------------

Resistance measurement

Range	100.00 Ω, 1.0000 kΩ, 10.000 kΩ, 100.00 kΩ, 1.0000 MΩ, 10.000 MΩ, 50.00 MΩ
Accuracy	0.1 Ω - 6 MΩ ±1.0% +2 6 MΩ - 50 MΩ ±2.0% +2

Conductance

Range / resolution	1nS - 60.00 nS / 0.01 nS
Accuracy	±1.5% +10

Specifications

Continuity measurement

Range / resolution	100.00 Ω / 0.01 Ω
Buzzer ON	$\leq 5 \Omega$
Buzzer Intermittent	$> 5 < 50 \Omega$
Buzzer off	$\geq 50 \Omega$

Frequency measurement

Range/resolution	100.00 Hz / 0.01 Hz 1.0000 kHz / 0.0001 kHz 10.000 kHz / 0.001 kHz 100.00 kHz / 0.01 kHz
Accuracy	$\pm 0.1\% + 2$

Capacitance measurement

Range / resolution	10.000 μF / 0.001 μF 100.00 μF / 0.01 μF 1.0000 mF / 0.0001 mF 10.000 mF / 0.001 mF 20.00 mF / 0.01 mF
Accuracy	$\pm 2.0\% + 2$ $\pm 5\% + 10 (> 1000 \mu\text{F})$

Diode test

Range / resolution	0 V + 2.800 V / 0.001 V
Accuracy	$\pm 1.0\% + 2$

Temperature

Type (AVO835 Only)	K
Range / resolution (AVO835 Only)	-20 $^{\circ}\text{C}$ to +1000 $^{\circ}\text{C}$ / 0.1 $^{\circ}$
Accuracy (AVO835 Only)	$\pm 1.0 \text{ }^{\circ}\text{C} + 20$

Environmental

Operational Temperature	-10 $^{\circ}\text{C}$ to +50 $^{\circ}\text{C}$ (14 $^{\circ}\text{F}$ to 122 $^{\circ}\text{F}$)
Operational Relative Humidity	$\leq 90 \%$ at 40 $^{\circ}\text{C}$ (104 $^{\circ}\text{F}$)
Storage Temperature	-30 $^{\circ}\text{C}$ to +70 $^{\circ}\text{C}$ (-22 $^{\circ}\text{F}$ to 158 $^{\circ}\text{F}$)
Storage Relative Humidity	$\leq 50 \%$ at 60 $^{\circ}\text{C}$ (140 $^{\circ}\text{F}$)
Altitude rating	2000 metres (6561.5 ft)
IP rating	IP54 Category 2

Non Contact Detection

Voltage range	95 Vac - 1000 Vac
Frequency range	50 Hz - 60 Hz

Supply**Batteries** 2 x AA (LR6) or 2 x NiMH (HR6)**Battery life (w/o backlight)** 150 hours**Automatic Stop** 10 Min.**Other features****Display count** 10000**IEC** IEC 61010**Safety rating** AVO830 - CAT IV 600 V
AVO835 - CAT III 1000 V / CAT IV 600 V**Dimensions** 200 x 100 x 38 mm**Weight** 430 g

11. Repair and Warranty

If the protection of an instrument has been impaired it should not be used, but sent for repair by suitably trained and qualified personnel. The protection is likely to be impaired if, for example, the instrument shows visible damage, fails to perform the intended measurements, has been subjected to prolonged storage under unfavourable conditions, or has been exposed to severe transport stresses.

New instruments are covered by a three year warranty from the date of purchase by the user, the second and third year being conditional on the free registration of the product at www.megger.com. You will need to log in, or first register and then login to register your product. The second and third year warranty covers faults, but not recalibration of the instrument which is only warranted for one year. Any unauthorised prior repair or adjustment will automatically invalidate the warranty.

These products contain no user repairable parts and if defective should be returned to your supplier in the original packaging or packed so that it is protected from damage during transit. Damage in transit is not covered by this warranty and replacement / repair is chargeable.

Megger warrants this instrument to be free from defects in materials and workmanship, where the equipment is used for its proper purpose. The warranty is limited to making good this instrument (which shall be returned intact, carriage paid, and on examination shall disclose to their satisfaction to have been defective as claimed).

Misuse of the instrument, from connection to excessive voltages, fitting incorrect fuses, or by other misuse is excluded from the warranty.

The instrument calibration is warranted for one year.

This Warranty does not affect your statutory rights under any applicable law in force, or your contractual rights arising from a sale and purchase contract for the product. You may assert your rights at your sole discretion.

11.1 Calibration, Service and Spare Parts

For service requirements for Megger instruments contact Megger or your local distributor or an authorised repair centre. Megger operates fully traceable calibration and repair facilities, ensuring your instrument continues to provide the high standard of performance and workmanship you expect. These facilities are complemented by a worldwide network of approved repair and calibration companies to offer excellent in-service care for your Megger products.

Refer to Megger contact details.

Local Sales office

Megger Limited
Archcliffe Road
Dover
Kent
CT17 9EN
ENGLAND
T. +44 (0)1 304 502101
F. +44 (0)1 304 207342

Manufacturing sites

Megger Limited
Archcliffe Road
Dover
Kent
CT17 9EN
ENGLAND
T. +44 (0)1 304 502101
F. +44 (0)1 304 207342

Megger GmbH
Weststraße 59
52074 Aachen
T. +49 (0) 241 91380 500
E. info@megger.de

Megger USA - Valley Forge
Valley Forge Corporate Center
2621 Van Buren Avenue
Norristown
Pennsylvania, 19403
USA
T. +1 610 676 8500
F. +1 610 676 8610

Megger USA - Dallas
4545 West Davis Street
Dallas TX 75237
USA
T. 800 723 2861 (USA only)
T. +1 214 333 3201
F. +1 214 331 7399
E. USsales@megger.com

Megger AB
Rinkebyvägen 19, Box 724,
SE-182 17
DANDERYD
T. +46 08 510 195 00
E. seinfo@megger.com

Megger USA - Fort Collins
4812 McMurry Avenue
Suite 100
Fort Collins CO 80525
USA
T. +1 970 282 1200

This instrument is manufactured in the United Kingdom.

The company reserves the right to change the specification or design without prior notice.

Megger is a registered trademark

The Bluetooth[®] word mark and logos are registered trademarks owned by Bluetooth SIG, Inc and is used under licence.