

Circuit Breaker Testing Guide

Megger[®]



CONTENTS

Introduction

Why test circuit breakers 4

Standards 5

A vital part of the power network

The circuit breaker 6

Disconnectors
and load switches 6

General CB function

Main and arcing contacts 7

Solutions to handle the arc 7

Synchronized / controlled function 8

Multiple breaks per phase 8

Resistor contacts 8

PIR 8

Opening resistors 8

Capacitors 8

Grading capacitor 8

Parallel capacitor 8

Application areas for CB

Generator CB 9

Transformer CB 9

HV circuit breakers 9

Capacitor bank CB 9

Reactor CB 9

High Voltage DC breaker 10

Distribution circuit breakers 10

Switch disconnectors 10

Traction CB 10

Main types of CB

DCB 11

Live-tank 11

Dead-tank 11

Low voltage CB 11

CB technologies

Air / Gas 12

Air circuit breakers (ACB) 12

Air blast 12

SF₆ 13

Vacuum 13

Oil 13

Bulk oil 13

Minimum oil 13

Important CB parts

Interrupter unit 14

Main contacts 14

Arcing contacts 14

Nozzle 14

Absorbing material 14

Operating mechanism 15

General functionality 15

Diverse operating mechanisms 15

Failure modes

Definition of failure – according to Cigré 16

Cigré CB survey 1981,1985 16

Maintenance aspects 17

Maintenance strategy

Maintenance approaches 18

Testing guide 19

How to test

Safety 20

Power utilities and instrument manufacturers practice 20

Step by step routines 20

DualGround testing 21

Timing with both sides grounded 22

Items to be tested / inspected 23

Test methods and parameters 23

First trip test 23

Contact timing 24

Main contacts 24

Primary injection test 24

Motion	25	Megger CB testing products – overview	
Static resistance measurement (SRM)	25	Circuit breaker analyzers	36
Dynamic resistance measurement (DRM)	26	TM1800	36
Coil test	27	TM1700-series	36
Minimum voltage test	28	EGIL	36
Minimum voltage required to operate breaker	28	EGIL 200	36
Vibration testing	28	Breaker Analyzer Program CABA Win	37
Vibration testing on circuit breaker	28	VIDAR	37
Vacuum bottle test	29	Auxiliary equipment	37
SF ₆ leakage	29	B10E	37
Humidity test	29	SDRM202	37
Air pressure test	30	Micro-ohmmeters	38
Mounting of motion transducer	30	MJÖLNER 200 and MJÖLNER 600	38
Test equipment		MOM2	38
Product selection guide	31	MOM200A and MOM600A	38
Good to know about error sources		DLRO200	39
Capacitive coupling	32	DLRO 247000 Series	39
Inductive coupling	32	Primary injection test sets	40
Disturbances	32	ODEN A and ODEN AT	40
Temperature	32	INGVAR	40
Voltage supply	32	CSU600A and CSU600AT	40
Connections, leads and clamps	33	Abbreviations and terms	
Transducer and flex coupling tolerances	33	Index	
Sampling frequency	33	References	
Inaccuracy	33	What's in the name...?	
Interpretation of the test results			
Failure mode analysis	34		
FAQ			



Introduction

Circuit breakers are some of the most important components in modern electric power systems. The circuit breaker has to operate within extremely tight tolerances when a disturbance is detected in the network to protect sensitive and costly components such as transformers. They have to operate after months or in some cases years of inactivity. To ensure proper function and optimize network reliability, reliable and efficient test instruments and methods are needed. New developments have made it possible to improve and re-evaluate conventional methods that sometimes involves time consuming and cumbersome process steps.

The aim of this publication is to increase the understanding of circuit breaker testing.

Why test circuit breakers

Some of the most important of the many reasons for testing circuit breakers are to ensure they:

- **Provide protection for expensive equipment**
- **Prevent outages that lead to loss of income**
- **Ensure reliability of the electricity supply**
- **Prevent downtime and darkness**
- **Verify breaker performance**

Substation breaker testing is an important task for any power utility. The breakers are there to facilitate the flow of current during normal operation and to interrupt current flow in the event of a fault. However, all electrically operated devices are, sooner or later, likely to experience some kind of failure. That failure can be caused by many factors, including ageing and external faults. The power utility operator has to be prepared and have a plan in place to handle every situation.

This document will help readers to understand what is involved with keeping circuit breakers operating at peak performance. Breakers are mechanically sophisticated devices requiring periodic adjustments. The need for some of these adjustments can be determined visually and they can be given the attention needed without testing. However, in most cases, it will be necessary to carry out electrical testing to find out what is the cause of out-of-tolerance conditions. This guide primarily deals with electrical testing.

HV Circuit Breakers in a transmission scheme can be viewed as forming a tree starting with the generating station, fanning out to the transmission grid, to the distribution grid, and finally to the point of consumption.

The task for the utility is to generate power, transmit it and distribute it with maximum availability. While doing this, it is

imperative that losses are kept to a minimum, and acceptable levels of power quality and safety are maintained. All of this must be done in an environmentally friendly manner. Breakers play an important part in making this happen. High voltage circuit breakers are extremely important for the function of modern electric power supply systems. The breaker is the active link that ultimately has the role of quickly opening the primary circuit when a fault occurs. Often, the breaker has to perform its duty within some tens of milliseconds, after months, perhaps years of idly being in circuit. Since RCM (reliability centred maintenance) and condition based maintenance have become the established strategies for most owners and operators of electric power delivery systems, the need for reliable and accurate test instruments for field use is clear.

Protection systems are put in place to detect all electrical faults or other abnormal operating conditions and they are coordinated to disconnect the smallest possible part of a power network in the event of a fault. With good system design, it should be possible to quickly restore normal operation. When a fault is detected by a protective relay and a trip impulse is sent to the breaker operating mechanism, the breaker has to function as specified and interrupt the current as soon as possible or severe damage may occur. The cost of damage caused by a malfunctioning circuit breaker can sometimes reach large sums.

Proper functioning of a breaker is reliant on a number of individual components that have to be calibrated and tested at regular intervals. The trigger for maintenance intervals differs greatly between power utilities but the intervals are often based on time since last test, number of operations, or severity of fault current operations. Environmental considerations such as humidity and temperature, whether the breaker is located in a desert or coastal region, also play into the maintenance scheme.

Mechanical wear and lubrication often affects the performance of breakers, so being able to trend mission critical parameters and compare these with factory thresholds helps to verify proper breaker function.

NORME
INTERNATIONALE
INTERNATIONAL
STANDARD

CEI
IEC
62271-108

Première édition
First edition
2005-10



High-voltage switchgear and controlgear –

Part 108:
High-voltage alternating current disconnecting
circuit-breakers for rated voltages of 72,5 kV
and above



IEEE C37.09-1999

IEEE Standard Test Procedure for AC High-Voltage Circuit Breakers Rated on a Symmetrical Current Basis

Institute of Electrical and Electronics Engineers / 28-Mar-2000 / 36 pages

Amendments: [IEEE C37.09b-2010](#), [IEEE C37.09a-2005](#)

Corrigenda: [IEEE C37.09-1999/Cor. 1-2007](#)

Standards

High voltage circuit breaker design and operation as well as type and routine tests are defined by international standards such as:

- IEC 62271-SER ed1.0 - High-voltage switchgear and control gear.
- ANSI/IEEE C37 - Guides and Standards for Circuit Breakers, Switchgear, Relays, Substations, and Fuses.
- IEC/TR 62063 ed1.0 (1999-08) TC/SC 17A - High-voltage switchgear and control gear - The use of electronic and associated technologies in auxiliary equipment of switchgear and control gear.



A vital part of the power network

Power transmission networks mostly use three-phase AC. High-voltage direct-current (HVDC) technology is used only for very long distances, submarine power cables or for connecting two AC networks that are not synchronized.

Electricity is transmitted at high voltages, 72 kV or above, to reduce the energy loss. Usually power is transmitted through overhead lines. Underground power transmission has a significantly higher cost and operational limitations but is sometimes used in urban areas or sensitive locations.

The circuit breaker

The general function of the circuit breaker (CB) is to close and open the circuit to be able to remove faults and connect/disconnect objects and parts of electricity network.

The circuit breaker is a part of the protection of the main components in the network, transformers and lines. The majority of the switching operations of a CB are normal-load operations.

When a fault is detected by a protective relay and a trip impulse is sent to the CB's operating mechanism, the CB has to function as specified and interrupt the current as soon as possible or severe damage may occur. The damage caused by a malfunctioning breaker can often reach millions of dollars.

Disconnectors and load switches

Disconnectors are used for physical isolation of the switchgear from the power system during maintenance work. They switch during no load conditions or only small currents. Disconnectors can carry load and fault current but not break a load. The function of a disconnector is to disconnect the network from objects in the substation and to change the switching arrangement. When a disconnector is open the disconnected object is accessible for service. The opening and closing of disconnectors are slow compared with CB.

Load switch (switch disconnector) is a type of switch that can break a normal load but not break a fault current. Load switches are only used on low and medium voltage and up to 245 kV for special applications.

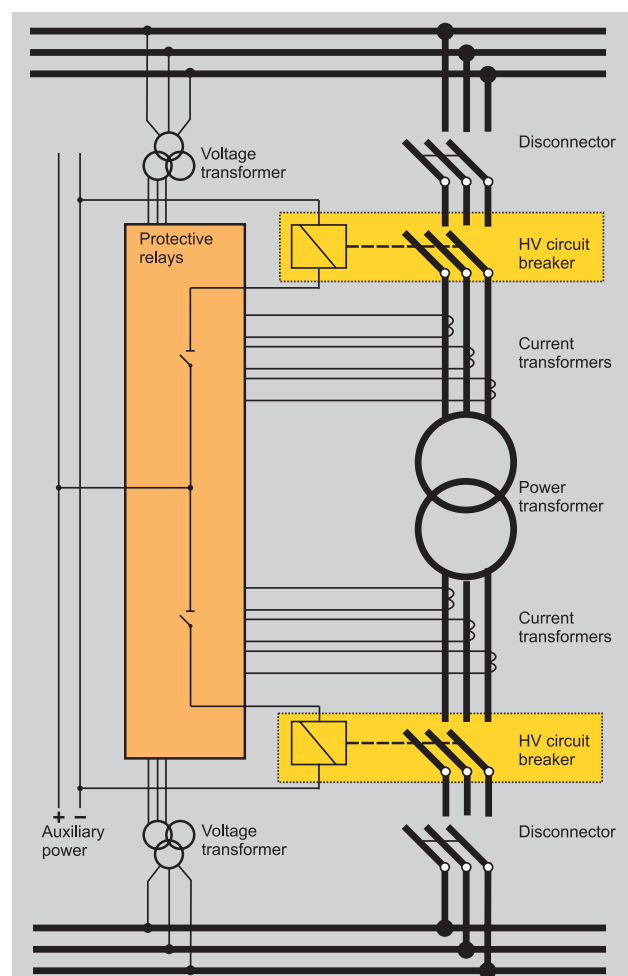

An overview of the components in a power grid system.

General CB function

Besides conducting and interrupting operating currents, the CB is designed to break fault currents, e.g. short-circuit currents, that can be 5 to 20 times the value of the rated current, within about 50 milliseconds. There are big challenges for the CB designers, some circuit breakers must be able to break currents up to 100 kA and others to handle voltages up to 1150 kV.

Main and arcing contacts

It is usual that SF₆ circuit breakers have two contact systems, the main contact system and the arcing contact system. The main contacts conduct the normal operating currents and the arcing contacts are used to take the load off the main contacts when the CB opens and closes. This will protect the main contacts from getting burned.

The arc created when the arcing contact system separates is extinguished at one of the next zero crossings of current. The convective and radiative heat from the arc causes a sudden rise in pressure in the 'heating volume' between the arcing contact system and the piston. It is from here that hot gas is blasted to extinguish the arc at the zero crossing.

Solutions to handle the arc

Although the arcing contacts are made to withstand the heat from the arc they are exposed to high stress. To handle this, there are different solutions:

- Synchronized / controlled functionality
- Multiple breaks per phase to divide the high voltage

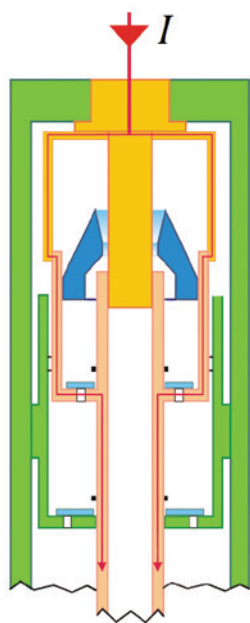

CB Closed position

Current flows through the main contacts

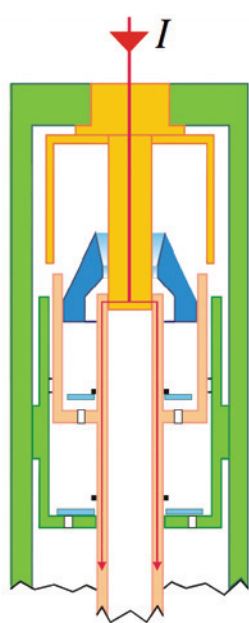

Opening of the main contacts

The moving part goes down thus separating the main contacts. There is no arc striking as the current keeps flowing from the upper terminal to the moving parts through the arcing contacts.

During the downstroke, the moving part exerts a pressure on the gas housed in the lower chamber; the pressure increase generated in the lower chamber opens the connection valve of the upper chamber. The compressed gas flows from the lower to the upper chamber thus equalising the pressures.

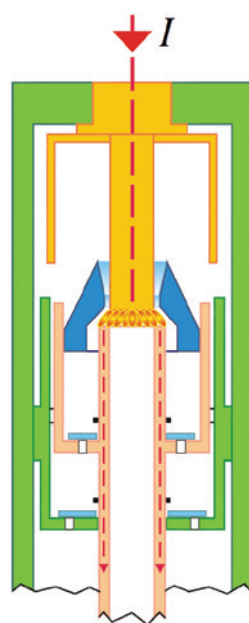

Opening of the arcing contacts

The current keeps flowing due to the arc generated between the fixed and moving contacts. The gas can not leak from the nozzle as the hole is blocked by the fixed contact or from the inside of the moving contact because of the arc clogging effect.

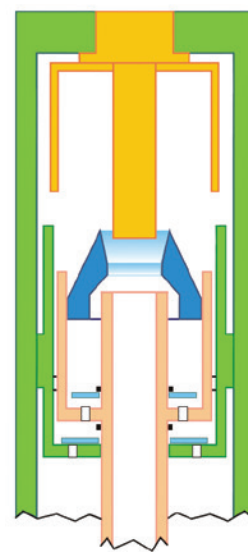

CB in open position

The arc is quenched; the lower chamber reaches its minimum volume and its maximum pressure level, kept by the valve locked by the supersonic wave. As the self-generated pressure of the dead volume decreases, due to the outflow of the gas through the moving contact, the valve re-opens. From now on, a new jet of fresh gas flows in and makes the temperature of the contacts fall. At the same time, the gas flows through the nozzle, free from the fixed arcing contact. The "cleaning" of the arcing chamber by means of fresh gas makes the device suitable for another reclosing and the interruption up to the maximum breaking capacity.

Synchronized / controlled function

Modern control systems attempt to exploit the ability to precisely and repetitively control the instant at which the breaker contacts operate. Most commonly controlled or synchronized switching is applied to capacitor banks and shunt reactors as well as power transformers and transmission lines. Since the behaviour of loads is different (capacitive and inductive) switching them requires adapted solutions.

Under ideal circumstances when switching in a capacitor bank there will be no current transients created if the breaker poles close at the instant of zero voltage. The optimal switching of a reactor on the other hand is different and is managed by switching two phases at the maximum voltage and third phase 90 degrees later, thus creating symmetrical energization currents. Optimal disconnection of the reactor is performed in a manner which eliminates the reignition of the arc in interrupter chamber. All these operations require precise timing and control of the three individual poles.

Controlled switching of circuit breaker where each breaker pole is synchronously actuated by a control unit based on the instantaneous values of the current or the phase to earth voltage are becoming increasingly important. For single-pole operated circuit breakers this is accomplished by sending individual control commands to each pole. In case of three-pole operated circuit breakers, with one common operating mechanism, the circuit breaker has built-in mechanical delays between the poles. The controller then sends the control command to the master pole and the other poles are delayed mechanically to realize the correct phase order

Multiple breaks per phase

To be able to break Extra High Voltage, EHV, many interrupters are connected in series, up to twelve for air blast breakers and up to four for modern breakers.

There were air blast breakers from the 1950s still in use in the 2009 with 8 breakpoints and 10 disconnecting points in series.

Resistor contacts

PIR

Preinsertion resistor (PIR) contacts are mainly used at higher voltages (362 kV and above). The main purpose of PIR contacts is to limit the transients on the network when reconnecting lines with no load. They are only used during close and are connected in parallel with the main contacts. The PIR contacts close about 8-12 ms before main contacts.

The pre-insertion resistor provides inrush limiting by the momentary insertion of a resistive device into the circuit before full energizing.

Opening resistors

Opening resistors, or damper resistors are used to dampen the restriking voltage which can appear during opening operations. They are mainly used on older types of CB, such as air-blast breakers.

Capacitors

Grading capacitor

Grading capacitors are sometimes used on circuit breakers with two or more interrupters in series to obtain uniform distribution of the voltage stresses across the open gaps.

The grading capacitor is connected in parallel with each interrupter unit and has a standard value in the range of a few nF/capacitor. The total capacitance across open gap is calculated as follows:

$C_{tot} = C_{gr}/n$ C_{gr} is the capacitance of each grading capacitor.

n is number of making/breaking units connected in series.

Parallel capacitor

Parallel capacitors are used to increase the short-circuit capability of circuit breakers.

The additional capacitance increases the time delay for the initial transient recovery voltage and has therefore an impact mainly on the short-line fault performance.

Line-to-ground capacitors have a similar effect as parallel capacitors but are mainly used on dead tank circuit breakers.

Application areas for CB

Depending on its application in the network the CB's service life differs. For instance, line circuit breakers operate seldom and have a longer service life than e.g. capacitor bank circuit breakers that operates normally twice a day.

- **Generator CB**
- **Transformer CB**
- **HV circuit breakers**
- Capacitor bank CB
- Reactor CB
- High Voltage DC CB
- **Distribution circuit breakers**
- Switch disconnector
- Traction CB
- Industrial CB

Generator CB

A generator circuit-breaker's performance needs to be far better than that of a line CB. The positioning of the generator circuit breaker between the generator and the step-up transformer, where its performance directly influences the plant output, places very high demands on its reliability.

Transformer CB

In a substation there is a circuit breaker located on each side of the transformers.

HV circuit breakers

Electrical power transmission networks are protected and controlled by high-voltage circuit breakers. The definition of high voltage varies but in power transmission context it is usually said to be voltage over 72 kV. High-voltage breakers are operated via protective relays with sensing through current and voltage transformers are operated via protective relays with sensing through current and voltage transformers.

Capacitor bank CB

Capacitor bank circuit breakers are under more stress than a normally incoming circuit breakers. They operates more frequently and switch with higher transient voltages.

Reactor CB

De-energization of the reactor results in very severe transient recovery voltages across the contacts of the high voltage circuit breaker. The severe transient recovery voltages are caused by the high frequency oscillation between the inductance of the reactor and its equivalent terminal-to-ground capacitance. Because of the relatively small reactive currents involved, circuit breakers tend to interrupt the reactive load currents at very small contact gaps, and usually while chopping the current. (Current chopping occurs when the current is prematurely forced to zero by the aggressive interrupting action of the circuit breaker). When the dielectric strength of the interrupting medium in the small contact gap is exceeded by the severe transient recovery voltage, the circuit breaker will reignite and interrupt at the next current zero, usually at a current-chopping level higher than that at initial interruption. Overvoltages across the reactor, and the severity of the transient recovery voltages across the circuit breaker contacts, increase as the current-chopping level increases. Thus, conditions are created that could result in insulation failure in the reactors, and a failure of the circuit breaker to interrupt.

Controlled opening of shunt reactors is mainly aimed to avoid the reignition of arc in breaker interrupter and is widely used. The application is rather straightforward and there are obvious economic benefits of having controlled switching equipment to reduce expenses for maintenance and possible failures.





High Voltage DC breaker

High voltage circuit breakers used for alternating current extinguishes the arc at the zero crossing of the current when opening, and thereby opens the circuit. However, with HVDC (High Voltage Direct Current) there is no zero crossing which means that the use of conventional circuit breakers for line protection is not applicable. Line faults can be cleared by, instead of tripping a breaker, controlling the voltage to zero from the HVDC converter station. For substation maintenance purposes, breakers are used as disconnectors, but only after reducing the current to zero. For example, on a 500 kV DC line, three 245 kV breakers put in series is only capable of breaking currents of approximately 50 A.

Distribution circuit breakers

Circuit breakers in distributing network up to a voltage level to about 70 kV.

Switch disconnector

A switch disconnector is a device capable of making, carrying and breaking rated current under normal service conditions. It is also able to carry the rated short circuit current and related peak current for limited time. A switch disconnector also satisfies requirement for an insulation distance specified for a disconnector in the open position.

Traction CB

Nominal voltage varies from 600 to 25 kV and some with low frequency. Breakers operate frequently and have to extinguish longer-burning arcs when in 16 2/3 Hz networks. This influences the service life and maintenance intervals.

Industrial CB

High voltage breakers are used for different industrial purposes e.g. big motors, ovens and melting furnaces.

Primary distribution vacuum circuit-breaker (15 kV) with integrated sensors and protection control unit.



Main types of CB

DCB

A Disconnecting Circuit Breaker (DCB), replaces the conventional combination of circuit breaker and separate disconnectors. The disconnecting function is integrated in the breaking chamber. That means that the circuit breaker fulfils all requirements for a circuit breaker as well as for a disconnector.

The design of a DCB is usually the same as to a standard circuit breaker except for that a higher voltage class is used and that there is a device to mechanically lock the DCB in open position. The advantage with the DCB is that it eliminates a separate disconnector switch, which also reduces the size of the substation. One disadvantage with the DCB is that the whole bus bar has to be taken out of service when performing maintenance on the DCB, since one side of the DCB will always remain energized.

Live-tank

On live-tank circuit-breakers, the interrupter chamber is isolated from the ground by an insulator which can be either of porcelain or of a composite material, and is at high potential. The voltage level determines the length of the insulators for the interrupter chamber and the insulator column. In live-tank circuit breakers no fault currents can occur between the interrupter unit and the housing, therefore only one current transformer per pole assembly is necessary. A further feature of live-tank circuit breakers are the comparatively small gas compartments. The advantage of the low gas volume is that there is a reduction in the amount of gas maintenance work.

Dead-tank

The distinguishing feature of dead-tank technology is that the interrupter chamber is accommodated in an earthed metal housing. With this design the SF₆ gas filling the tank insulates the high voltage live parts of the contact assembly from the housing. Outdoor bushings connect the interrupter chamber with the high-voltage terminals.

This construction means an increased risk of internal earth fault or short circuit within the tank and the risk cannot be neglected. To handle those situations the bushings on both sides of the tank are normally equipped with current transformer further connected to protective relays.

The dead tank circuit breaker has an advantage in case of earth-quakes.

Low voltage CB

Low voltage circuit breakers types are common in domestic, commercial and industrial applications up to 1000 V AC.

A Moulded Case Circuit Breaker (MCCB) can be rated up to 2500 A. They are thermal or thermal-magnetic operated. These CBs are often installed in draw-out enclosures that allow removal and interchange without dismantling the switchgear. Some large MCCBs are remotely operated by electrical motors, often part of an automatic transfer switch system for standby power.



Disconnecting circuit-breaker. Same contacts for switching and disconnecting functions.



Live tank circuit breaker



Dead tank circuit breaker

CB technologies

Circuit breakers can mainly be divided into three groups depending on medium that encloses (insulates) the breaker contacts. In one group, it is air or other gas, in the second vacuum and in the third oil.

■ Air / Gas

- ACB
- Air blast
- SF6

■ Vacuum

■ Oil

- Bulk oil
- Minimum oil

The SF₆ insulated circuit breakers are more or less the only installed type within transmission networks today, mainly due to its relative high total rating and characteristic in relation to its price. However, with new improvements with vacuum breaker design they are also becoming more common at the lower voltage ranges of the transmission networks. Today they can handle voltages up to 252 kV but are still very expensive. The vacuum breakers are more commonly installed at system voltage levels of 70 kV and below. Both the SF₆ and vacuum circuit breakers are very common in today's distribution networks.

Substations are often built as air-insulated switchgear (AIS), using open air as insulating medium between the different phases and devices.

Gas-insulated switchgears (GIS) are designed and assembled by a combination of standardized function modules such as circuit breakers, disconnectors, earth-switches, current and voltage transformers, and supplementary modules. The major advantage with a GIS installation is the reduction of space required compared to the air-insulated substations. The maintenance and test interval for circuit breakers installed in a GIS is also longer compared to AIS.

Air / Gas

Air circuit breakers (ACB)

ACBs can be used both as circuit breakers of low voltage electrical distribution systems and for protection of electrical equipment in facilities and industries.

A common breaking principle is to use the magnetic field, created by the current through the ACB, to force the arc towards insulating lamells. As the arc goes further in between the lamells eventually the distance to maintain the arc is exceeded and it is extinguished.

Air blast

The air blast circuit breakers came into use in the 1930s and became the common circuit breaker on high voltage and very high voltage applications. The robust designs were reliable and robust but noisy. Many breaks are needed for high voltages and they are commonly found with opening resistors.

Air is compressed in a reservoir up to 14 bar. The contacts are opened by air blast produced by opening a valve. The compressed air is released and directed towards the arc at high velocity. The air blast cools the arc and sweeps the arcing products away. This increases the dielectric strength of the medium between contacts and prevents re-establishing the arc. The arc is extinguished and the current is interrupted. The short arcing time, compared with oil CB, gives low impact on the main contacts.



MCCB (Moulded Case Circuit Breaker) is one example of ACB 500 A / 600 V



Vacuum circuit breaker cut-away

SF₆

Sulphur hexafluoride (SF₆) is an inert, heavy gas having good dielectric and arc extinguishing properties. The dielectric strength of the gas increases with pressure. It is an electro-negative gas which means that the free electrons are attracted to the gas and are not free to move. The consequence of this characteristic is a high dielectric strength. Arcing can produce a number of more or less toxic decomposition by-products that places high demands on recycling and disposal of the gas.

SF₆ circuit breakers suffer less wear on the main contact than air and oil circuit breakers. The breaking principle is to cool down the arc by blowing gas with high pressure towards the arcing contacts.

There are two main types; puffer and self-blast. The puffer type creates the gas pressure using a piston pump whereas the self-blast takes advantage of the pressure created by the heat from the arc. The advantage of the puffer type is that it has good breaking properties for all current levels. The disadvantage is that it requires more mechanical force to operate, requiring a bigger operating mechanism. The advantage of the self-blast is that it requires up to 50% less energy than the puffer breaker to operate but it has less good breaking properties.

Vacuum

Vacuum breakers are used up to 70 kV. Because there is no gas to ionize to form the arc, the insulating gap is smaller than in other circuit breakers. An arc does form from the vaporized contact material. The insulation distance in a vacuum breaker is about 11-17 mm between plates. Normally there is one breaker per phase but there can be two interrupters in series.

The contact plates are formed to conduct the current in a way that creates a magnetic field that causes the arc to rotate and extinguish. A benefit with a rotating arc is uniform heat distribution and that the contacts get more evenly eroded. Other advantages with vacuum breakers are their relatively long operational life time and their relatively limited impact on the environment since they are designed without poisonous gases and relative few components. Vacuum circuit breakers also suffer less wear on the main contact than air and oil circuit breakers.

Oil

Bulk oil

The current interruption takes place in oil tank. The oil cools and quenches the arc and is also insulating. This type has mainly been used at the distribution level and demands a lot of maintenance on the main contacts.

Minimum oil

It is used in transmission and substation and require small amount of oil and it operates very fast.



Circuit breaker, 1000 kV

Important CB parts

Interrupter unit

Main contacts

The main contact in a circuit breaker is the current carrying element between the stationary- and the moving part of the interrupter, and thus, a big surface with very low resistance (less than 100 mΩ) is vital for a long service lifetime.

Silver-coated copper is the most common material used for main contacts.

Arcing contacts

The arcing contact is a contact in parallel with the main contact and takes care of the arcing during separation. This type of contact is common on many types of circuit breakers. The arcing contact releases later than the main contact .

A circuit breaker suffers arcing contact wear during normal operation as well as when breaking short-circuit currents. If the arcing contact is too short or otherwise in bad condition, the breaker becomes unreliable. The main contact surfaces can be degraded by arcing, resulting in increased resistance, excessive heating and in worst case explosion.

The arcing contacts are partly made of harder materials such as tungsten or graphite, to make them stronger

Nozzle

The nozzle is a part in a SF₆ circuit breaker separating the main contact from the arc as well as guiding the gas the correct way through the chamber in order to obtain an efficient quenching of the arc.

Absorbing material

When severe arcing occurs in the breaker, the SF₆ decomposes and by-products such as sulphur dioxide and sulphur fluorides are created. These by-products combine with any moisture in the gas resulting in sulphuric acid which is highly corrosive and can damage the inside of the breaker. By using desiccants, which absorbs these by-products and any moisture, the breaker can be protected.

Old design

New design

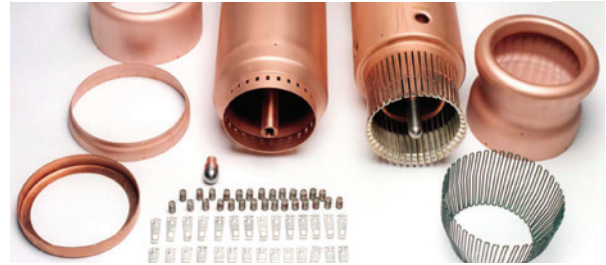

Example of simplified design. Current conducting parts of HV interrupter with integrated contact fingers

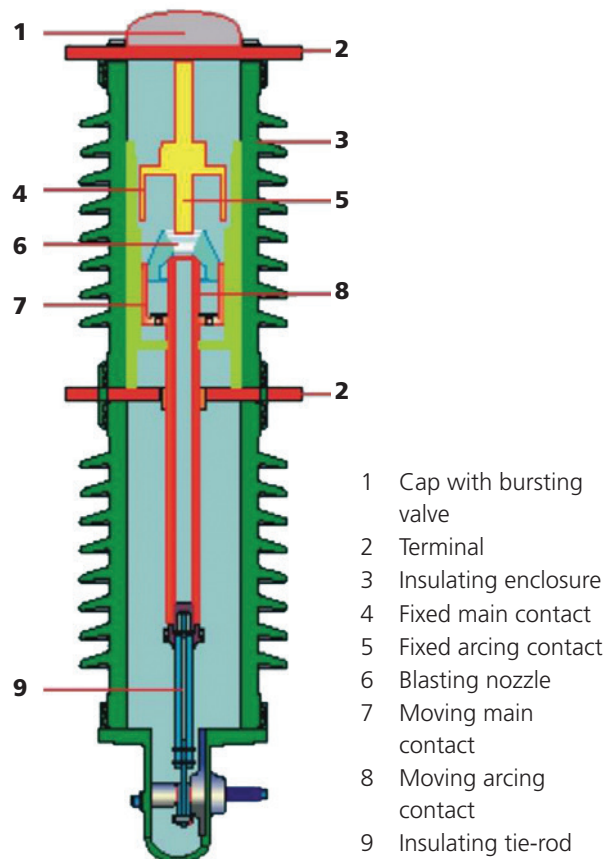

Cross section of a CB.

Operating mechanism

A large majority of operating mechanisms are designed to be trip-free. This means that the circuit breaker can perform a complete opening operation, even if the trip command is activated during a closing operation and with the closing command maintained.

A problem is that circuit breakers are not operated often enough. It may remain closed for days, weeks or even years on end. The static loading on bearings causes the lubrication to be displaced so that the bearing ultimately reaches a state of zero lubrication. So friction will then be very high during the initial movement. Greases and oils also tend to increase in viscosity at low temperature and they can also solidify by time and lack of movement.

General functionality

Auxiliary contacts and coil

Electromagnetic coils are used to control the operation of most types of circuit breakers. They are fast and reliable but a common cause of trouble of the circuit breaker as they can burn or get stuck in position.

The auxiliary contacts are contacts that follow or have an opposite position to the main contact. One important task for an auxiliary contact is to disconnect the coil when it has operated. The coil is disconnected to prevent damage as it is designed to be temporarily energized.

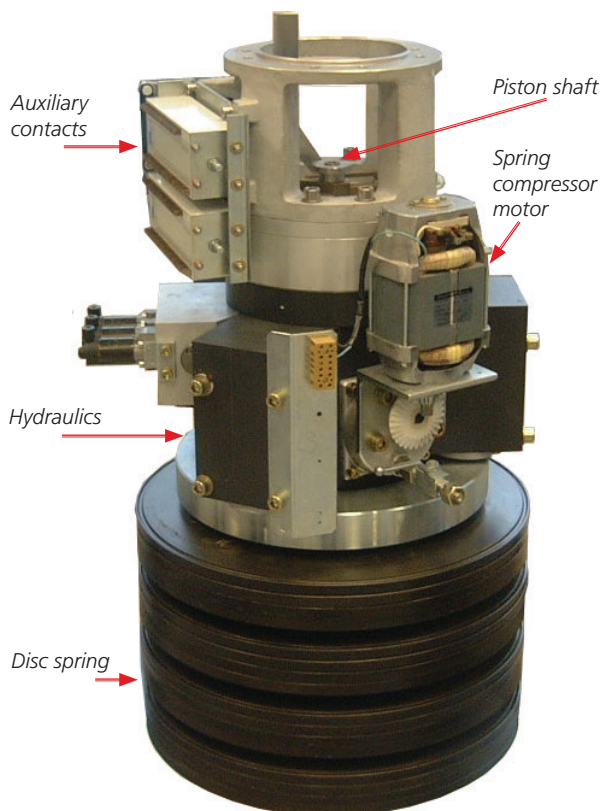

Hydraulic / spring loaded mechanism

Diverse operating mechanisms

Spring loaded

The spring operated mechanism is a mechanic actuating system using a spring as energy storage. The spring is tensioned with an electric motor and held by a latch system. When the breaker trips the latch is released by magnetic force. The spring energy moves the contacts by mechanic power transmission. Commonly there are separate springs for the open and close functions.

Hydraulic / Gas pressure

The hydraulic operating mechanism has a nitrogen accumulator for storing the actuation energy. The hydraulic fluid is pressurized by a compressed cushion of nitrogen. A hydraulic piston transmits the power to actuate the breaker contacts.

Hydraulic / Spring

This mechanism is a combination of hydraulics and springs. Energy is stored in a spring set which is tensioned hydraulically. Power is transmitted hydraulically to operate the CB contacts.

Pneumatic

There are a number of different designs of pneumatic operating mechanisms. Common for most types are that the energy is stored as compressed air in an air receiver (reservoir) and that the air pressure is converted to mechanical movement via a piston. Some types use a combination of spring and air pressure where the spring usually manages the closing operation and the air pressure the open operation. In these configurations it is common that the closing spring is charged during the open operation. In SF₆ and oil circuit breakers the mechanical power is transferred from the piston or spring to the moving contacts via a link system whereas on air blast circuit breakers the piston and the moving contact, as well as the closing spring and air blast ports, are integrated in the interrupting unit resulting in very few moving parts.

Motor

On command, the required operations are executed according to the stored contact travel program and the motor is controlled to move the circuit breaker primary contacts accordingly. Energy charging, buffering, release and transmission are essentially electrical and as such the mechanical system is reduced to a minimum of moving parts.

Thermal / Magnetic

Current flowing through the circuit heats the bi-metal current sensor, causing it to bend, this releases the armature and a spring forces the contacts to open. The load current also flows through a coil which creates a magnetic field that will trip the armature faster than the bi-metal strip can respond when very large currents flow.

Failure modes

Definition of failure – according to Cigré

Failure

Lack of performance by an item of its required function or functions.

Note: The occurrence of a failure does not necessarily imply the presence of a defect if the stress or the stresses are beyond those specified.

Major failure

Failure of a switchgear or control gear which causes the cessation of one or more of its fundamental functions. A major failure will result in an immediate change in the system operating conditions, e.g. the backup protective equipment being required to remove the fault, or will result in mandatory removal from service within 30 minutes for unscheduled maintenance.

Note: Or will result in unavailability for required service.

Minor failure

Failure of an equipment other than a major failure or any failure, even complete, of a constructional element or a sub-assembly which does not cause a major failure of the equipment.

Cigré CB survey 1981,1985

Results from a Cigré survey published in Electra No 79, 1981 and additional Cigré studies from 1985 covers the time interval 1974-77. All types of circuit breakers with service voltage above 63 kV are included.

Main results

- 70% of Major Failures (MF) were of mechanical origin
- 19% of MF were of electrical origin concerning the auxiliary and control circuits
- 11% of MF were of electrical origin concerning the main circuit
- 48% of MF were classified as “Does not open or close on command”

The operating mechanism was the part of the circuit breaker responsible for the highest number of failures (37% of MF).

Rated voltages 63-800 kV

Different types of operating mechanism have about the same major failure rate.

Mechanism type	Failures per 100 cb-years	
	Major failures	Minor failures
Hydraulic	0.31	2.89
Pneumatic	0.27	0.80
Spring	0.27	0.40

Most of the minor failures of operating mechanisms are either hydraulic oil or air leakages. The relationship between the minor failure rates of spring, pneumatic and hydraulic drive systems is 1:2:7 respectively.

Cigré CB survey 2005

Major failures sorted by originating component		
	1988 - 91	2004 - 05
Component at service voltage	21%	26%
Electrical control and auxiliary circuits	29%	22%
Operating mechanism, including kinematic chain	50%	52%

Common faults	
Does not close on command	34%
Does not open on command	14%
Breakdowns (poles, ground)	8%
Operates without command	7%
Others	<5%

Faults in components	
Operating mechanism	70%
Interrupters	14%
Insulation	6%
Frame/foundation	6%
Others	5%

Major failures segmented by failure mode

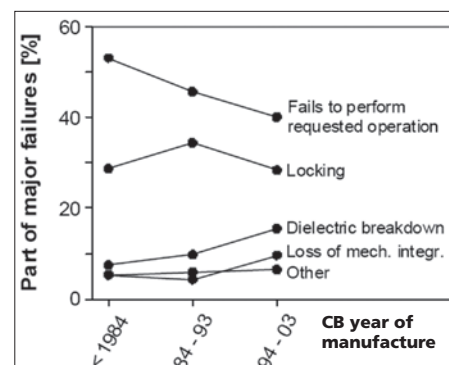

Major failures segmented by failing sub-component **Maintenance aspects**

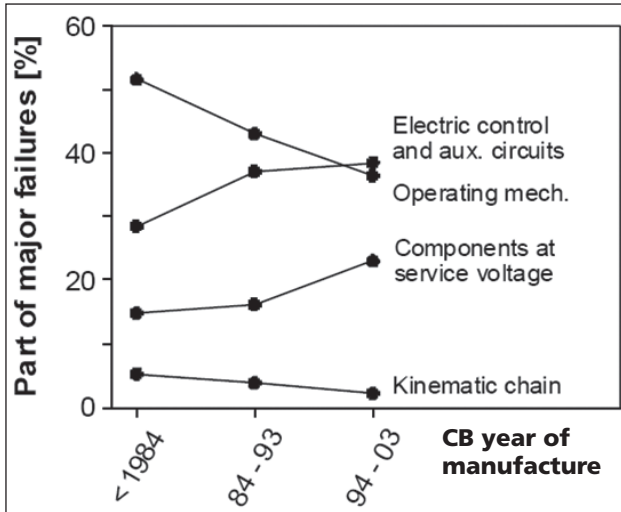

The operating mechanism remains the most unreliable part of the breaker.

“Does not close/open on command” and “Locked in open or closed position” remain the most frequently occurring failure modes.

The overall circuit breaker major failure rate appears to be substantially lower than in the previous survey.

Mechanical aspects

A large part of the major failures have mechanical origin. The operating mechanism and the electrical control and auxiliary circuits are the components responsible for the majority of both major and minor failures. The dominant major failure modes are “Does not open or close on command” and “Locked in open or closed position”. These modes add up to almost 70% of the major failures.



Generator circuit breaker failure

The average interval between scheduled overhaul is 8.3 years. This could in many cases be extended.

The number of failures caused by incorrect maintenance has decreased compared to the first enquiry (85% decrease for major failures, 26% for minor failures), but there is still room for improvement

About a quarter of the failures are caused by inadequate instructions and incorrect erection, operation and maintenance.

The three important issues for breaker maintenance are:

- Lubrication
- Contact adjustment
- Neglect or lack of maintenance

Briefly, the most important thing for breaker maintenance is grease. All breakers use grease as lubricant, and grease tends to dry out over time due to the heat produced in the breaker parts carrying the load.

Conclusions

The results from the latest survey is preliminary and the final report is soon going to be released. However, one can see that the reliability surveys show positive trends; the HV circuit breakers are getting better.

The reliability surveys have:

- Helped users to choose optimal equipment and maintenance procedures
- Helped manufacturers to improve their products
- Contributed to improvement of international standards



A distribution circuit breaker pole totally damaged by explosion.

Maintenance strategy



Connection of cables and clamps on a distribution CB.

Whatever form of maintenance approach is selected, the most important goal is to achieve maximum reliability at the lowest possible life cycle cost.

Since breaker testing many times is based on comparison and trend analysis it is important to strive to have the same conditions from test to test. High precision signal acquisition is also necessary, together with high measurement accuracy and a reliable means of storage for data.

If the set up work required can be minimized and the connection from the test instrument to the apparatus can be simplified, faster testing and evaluation of results can be achieved.

Testing can be done at various stages in the life of a CB including:

- **Development**
- **Production**
- **Commissioning**
- **Maintenance/fault tracing**
- **After service (re-commissioning)**

Maintenance approaches

Various power utilities, people and organizations have different viewpoints on and approaches to maintenance strategies. Testing and maintenance methodologies have changed over the years and in all likelihood they will continue to evolve as new technologies become available. This section is only intended to create awareness about some of the possible approaches. There are no correct or incorrect strategies, but there is sometimes a better way of doing things.

Approaches to maintenance include but are not limited to the following:

■ Reliability centred maintenance

Predictive maintenance but with value/importance priorities taken into consideration. The primary aim here is to preserve system functions by determining the criticality of individual components, etc.

■ Corrective maintenance

When something has already happened. If a maintenance strategy that is strictly corrective is adopted, no attempts are made to deal with a developing circuit breaker fault before it becomes fatal. This does not, however, ensure the reliable supply of electric power that consumers are entitled to expect. Short-term savings in maintenance costs will soon be eaten up by the cost of the damage and the cost of correcting a fault.

■ Preventative maintenance

Based on time or number of operations. It includes inspection, testing, overhauls and modifications. This strategy is encountered more frequently.

■ Periodic / time interval based maintenance

Carried out at regular intervals. In time interval-based maintenance, a number of specific measures are taken at predetermined times, regardless of the conditions under which a circuit breaker operates. If this method is applied too strictly, however, it may lead to needless intervention. Disassembling a circuit breaker that has no faults entails needless expense, and it does not improve reliability.

■ Condition based maintenance

A maintenance flag is set. The breaker's need for maintenance is based less on time than on the conditions to which it is exposed, how frequently it operates and its environment. Condition-based maintenance provides excellent opportunities to improve reliability and cut costs, but it requires effective diagnostic methods. Many circuit breakers provide longer service lives than expected.

■ **On-line testing**

Condition check without/taking CB out of service. Gives valuable information in relatively short time. Test methods that are available for on-line testing are:

- First trip / first close test with analysis of coil currents
- Vibration test

- Main contact timing through sensing of CT secondary current
- Auxiliary contact timing
- Control voltage measurement
- Motion measurement (under certain conditions)

Testing guide

Type of CB Voltage levels (kV)	Vacuum	Oil	Minimum Oil		SF ₆			Air-blast			GIS
	1 – 36	Any	6 – 145	145 – 400	6 – 40	72 – 245	>245	6 – 40	40 – 130	>130	Any
Application											
Timing	x	x	x	x	x	x	x	x	x	x	(x) ¹
Motion	(x) ²	x	x	x	x	x	x	(x) ³	(x) ³	(x) ³	x
Coil current	x	x	x	x	x	x	x	(x) ²	(x) ²	(x) ²	x
DRM	n/a	(x) ²	(x) ²	(x) ²	x	x	x	(x) ²	(x) ²	(x) ²	(x) ⁶
SRM	x	x	x	x	x	x	x	x	x	x	(x) ¹
Vibration	(x) ²	(x) ²	(x) ²	x	(x) ²	x	x	(x) ²	(x) ²	(x) ²	x
DCM	(x) ²	x	x	x	x	x	x	x	x	x	(x) ¹
Motor current	x	x	(x) ⁴	(x) ⁴	(x) ⁴	(x) ⁴	(x) ⁴	n/a	n/a	n/a	(x) ⁴
Min. voltage to operate CB	x	x	x	x	x	x	x	x	x	x	x
Minimum voltage	x	x	x	x	x	x	x	x	x	x	x
Station voltage	x	x	x	x	x	x	x	x	x	x	x
Gas density		n/a	n/a	n/a	x	x	x	n/a	n/a	n/a	n/a
Voltage integrity	x	n/a	n/a	n/a	n/a	n/a	n/a	n/a	n/a	n/a	n/a
Air pressure/flow	n/a	n/a	n/a	n/a	n/a	n/a	n/a	x	x	x	n/a
PIR contacts	n/a	x	(x) ⁵	(x) ⁵	(x) ⁵	(x) ⁵	(x) ⁵	(x) ⁵	(x) ⁵	(x) ⁵	(x) ⁵
Grading capacitors	n/a	n/a	n/a	(x) ⁵	(x) ⁵	(x) ⁵	(x) ⁵	(x) ⁵	(x) ⁵	(x) ⁵	(x) ⁵
Legend											
x	Applicable										
(x) ¹	If accessible										
(x) ²	Possible										
(x) ³	Optional – if disconnecter knife/contact is included in CB design.										
(x) ⁴	Motor current is only applicable on spring drives.										
(x) ⁵	Applicability and presence of grading capacitors as well as PIR contacts are depending on network design and not related to CB design.										
(x) ⁶	If accessible and if not vacuum CB										
n/a	Not applicable										
Comments											
Motor current	There are three different types of operating mechanisms; Spring, hydraulic and pneumatic. Motor current is only applicable on spring drives.										
PIR contacts Grading capacitors	Applicability and presence of grading capacitors as well as PIR contacts are depending on network design and not related to CB design. Usually not used in distribution networks.										
Oil CBs	Well defined travel trace and transducer attachment points. At higher voltages serial contacts per phase but those cannot be accessed, thus only timed as single contacts per phase. If PIR contact those are often sliding contacts in the main tank. No separation possible. Has to be timed as parallel contacts. PIR values can be down to 10 Ω. Coil current traces are essential. Always single operation mechanism if single tank design.										
Minimum Oil CBs 6 – 145 kV	1 contact / phase, single operating mechanism.	Coil currents are essential, as well as operating mechanism damping dash-pots. Travel is essential and it is usually relatively easy to find documentation on transducer attachment points etc.									
Minimum Oil CBs 145 – 400 kV	2-6 contacts / phase. 400 kV always separate (3) operating mechanisms.										

How to test



Circuit breaker grounded during preparation for timing test

Tests shall be made according to applicable standards, local regulations and best practice. The instruction material and the name plate for the circuit breaker can also be useful to assist the test. The safety aspect is of high importance – be careful to follow all safety instructions and regulations.

Before testing make a visual inspection to see if there are any signs of damage.

An important requirement for the CB is reliability. After a long time without being operated it shall function perfectly when needed. To test this you have only one chance to make a “first trip test”, described later in this chapter.

The rated operating sequence (also known as standard operating duty or standard duty cycle) is the specified operating sequence, which the circuit breaker shall be able to perform at specified ratings. Breaker manufacturer normally specifies these sequences and corresponding rated times, which are defined as per IEC 62271-100.

The main topics covered in this chapter are:

- **Safety**
- **Items to be tested / inspected**
- **Test methods and parameters**
- **Mounting of motion transducer**

Safety

The best way to improve personnel safety when working in a substation is to increase the distance between personal and devices with voltage. Regulations and laws require all objects to be grounded on both sides before any maintenance work. For circuit breaker maintenance the most basic and important test, main contact timing, is performed without this basic safety prerequisite. Conventional technology does quite simply not permit a safe way of timing a circuit breaker but now it is possible to test much safer using the DualGround (DCM) technology, see next pages.

Power utilities and instrument manufacturers practice

Before connecting the instrument to mains outlet, connect the separate ground lead to test/work ground and when disconnecting the instrument, disconnect the instrument from mains outlet and last disconnect the test/work ground.

Most substations have a common ground system and no additional actions need to be taken. In substations having separate ground systems, two alternatives are possible:

- **Temporary connect the two ground systems (E.g. ESA 99)**
- **Use an isolating transformer powering the test instrument (E.g. 1910.269(i)(2)(ii)C)**

If none of these actions are performed the instrument protective ground act as connection between the two ground systems. This can lead to a high current through the systems protective ground leads that the system is not designed for and is a risk for personal safety.

Step by step routines

- **Both sides grounded when connecting and if possible when measuring (DualGround).**
- **Ground instrument.**
- **Short ground leads.**
- **Don't leave circuit breaker open when grounded on one side.**
- **Remove connections in correct order.**

DualGround testing

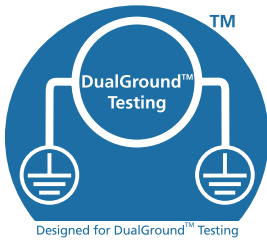

- **Increased safety for field personnel**
- **Suitable for all kinds of circuit breakers**
- **Non-intrusive and does not require any beforehand information**
- **Interpretation and way of working is not changed. Only made faster and easier**

A technology from 2006 that makes main contact timing of a circuit breaker possible with both sides grounded. Therefore dangerous voltage can be kept at distance. A safe area around the circuit breaker can be created and clearly marked with security fencing. Accidents with electric arc and electrocution can be avoided. The result of a main contact timing based on this new technology is in no way different for an interpreter and fully compatible with the conventional main contact timing measurement. For the field personnel the way of working becomes somewhat faster but otherwise remains familiar.

Timing of main contacts can today be performed using the DualGround method. This is a revolutionary method that allows for testing the circuit breaker accurately, more safely and efficiently compared to conventional timing. Safety procedures dictate that both sides of a breaker should be grounded when working on the breaker in field tests. Conventional timing methods require ground to be lifted on one side of the breaker to allow for the instrument to sense the change in contact status. This procedure makes the test cables and the instrument a part of the induced current path while the test is performed. The DualGround method allows for reliable measurements with both sides of the circuit breaker grounded thus making the test faster and easier. This technique also makes it possible to test circuit breakers in configurations such as GIS applications, generator breakers, and transformer applications where conventional timing methods requires removal of jumpers and bus-bar connections which is difficult and cumbersome.

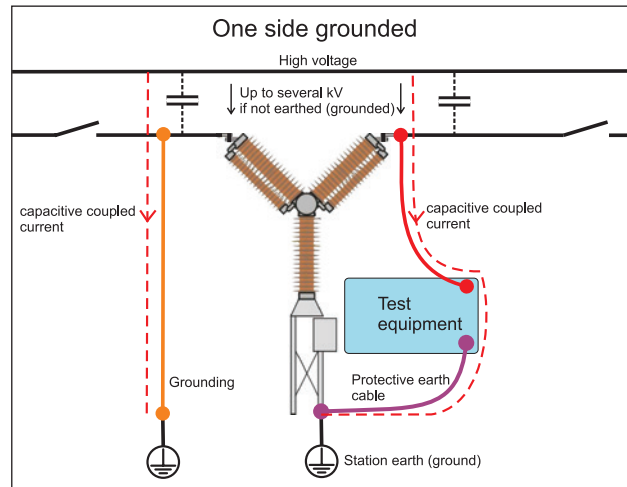

With only one side grounded the capacitive coupled current can reach values high enough to be harmful or lethal for humans.

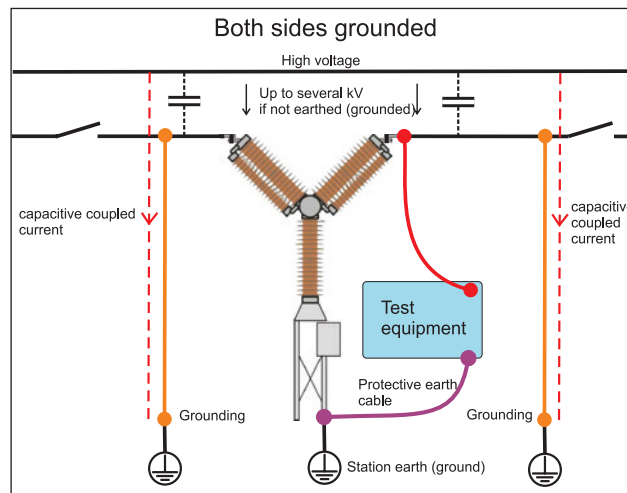

Testing is much safer using DualGround.

Conventional vs. DualGround	
Site preparation (isolate work area, apply safety ground, issue permit to work)	Site preparation (isolate work area, apply safety ground, issue permit to work)
Hook up test equipment. Issue sanction for test	Hook up test equipment. Issue sanction for test
Authorised person removes the ground	Risky step left out
Perform testing	Safe testing with both sides grounded
Authorised person applies ground	Risky step left out
Cancel sanction for test. Disconnect test equipment	Cancel sanction for test. Disconnect test equipment
Site closing (cancel permit to work, disconnect ground)	Site closing (cancel permit to work, disconnect ground)

Timing with both sides grounded

Timing measurements are difficult to make with both sides of a circuit breaker grounded. However, the Megger DualGround™ timing (DCM – Dynamic Capacitance Measurement), patented, is outstanding when ground loop resistance is low. The solution has no lower limit in ground loop resistance. The ground loop can even have lower resistance than the main contact/arcing contact path and it still works. This is particularly crucial when testing GIS breakers and generator breakers but also for AIS breakers having decent grounding appliances. The reason for the superiority of using DualGround with the DCM method is that it uses high frequency to achieve resonance in the test circuit. The fact that the resonance frequency varies when the circuit breaker changes state can easily be used for close/open detection.

There are other methods that use dynamic resistance measurement (DRM) as a means of timing a CB with both sides grounded. A current is injected and the voltage drop across the CB is recorded, then the resistance can be calculated. The determination of breaker state is simply estimated by evaluating the resistance graph against an adjustable threshold. If the resistance is below the threshold the breaker is considered closed and if the resistance is above the threshold the breaker is considered open. The problems arise when it comes to setting this threshold since it has to be below the ground loop resistance (which is initially unknown) and above the resulting resistance of the arcing contact (which also is unknown) and the ground loop in parallel. The reason for this is that according to the IEC standard it is the closing/opening of the arcing contact that counts as the breaker's operation time, not the main contact, and the difference between main and arcing contact operation time can, depending of contact speed, reach values approaching 10ms. A copper grounding cable 2 x 10 m with 95 mm² cross

section area has a resistance of about 3.6 mΩ (not counting transitional resistances in connector devices). An arcing contact is usually also in the milliOhm range, from a couple of milliOhms up to about 10 mΩ depending on the type of breaker but also on the condition of the arcing contact. All this together makes it an arbitrary task to adjust thresholds as you don't know what value to use. You will have to try different values until you get a reasonable result.

Furthermore, if you cannot view the resistance graph, because it is not recorded by the used test instrument, the threshold adjusting task becomes even more difficult.

Finally, a method built on evaluation against thresholds is more sensitive for induced AC currents through the test object. When grounding the circuit breaker in both sides a loop is formed with big area exposed to magnetic fields from surrounding live conductors. The alternating magnetic field will induce a current in the circuit breaker/grounding loop. This current can reach two digit Ampere values which would, in case of e.g. 100 A test current, correspond to a reasonable part. If the evaluation threshold is on the limit these current fluctuations would definitely affect the timing results.

The Megger DualGround DCM solution is completely insensitive for 50/60 Hz interference.

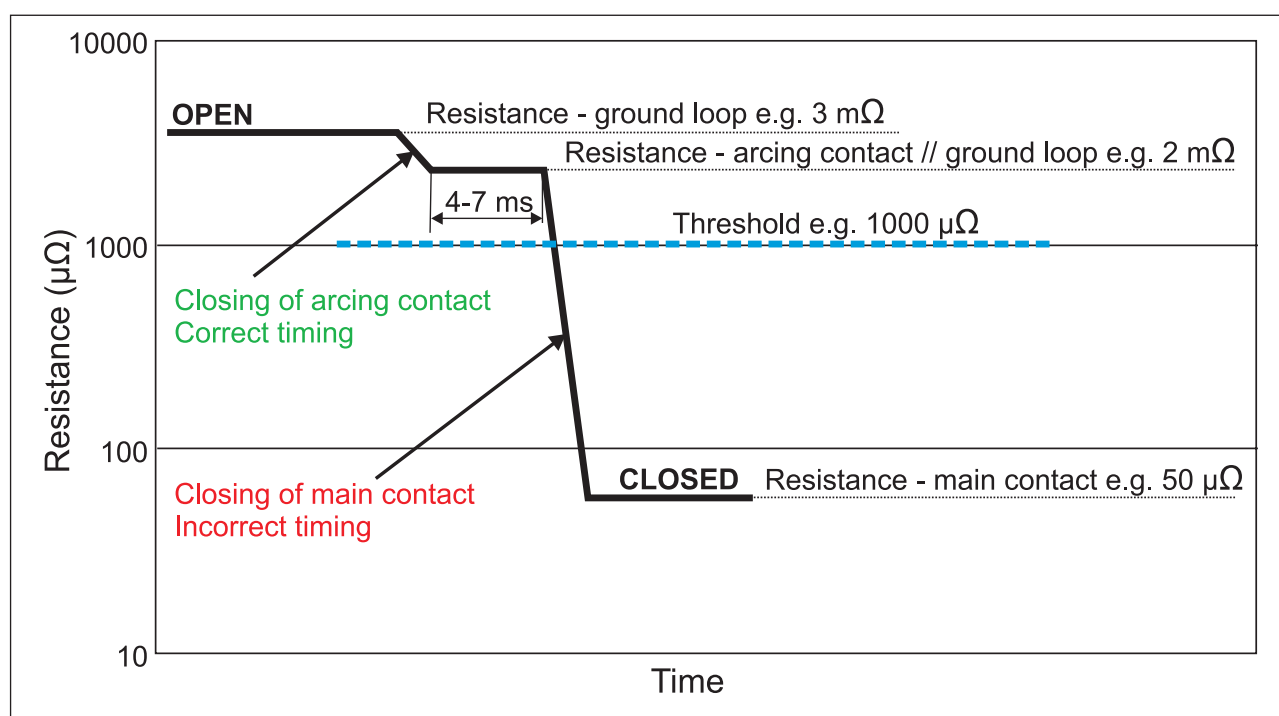

According to the IEC standard it is the closing/opening of the arcing contact that counts as the breaker's operation time, not the main contact.

Examples showing the problems finding threshold setting:

Threshold > 3 mΩ » Continuously closed

2 mΩ < Threshold < 3 mΩ » Correct closing time (to set the threshold within these limits is a bit of a lottery)

50 µΩ < Threshold < 2 mΩ » Incorrect closing time (e.g. 1000 µΩ in the diagram)

Threshold < 50 µΩ » Continuously open

Items to be tested / inspected

- Operating mechanism / Electrical accessories
- Arcing and main contacts
- Arcing chambers
- Main circuit - Busbars - Isolating contacts
- Grounding pliers (only for draw out power circuit breaker)
- Grounding connection (only for fixed power circuit breaker)
- Auxiliary circuit power supply voltage

Test methods and parameters

- First trip test
- Contact Timing
- Primary injection test
- Motion
- Static resistance measurement (SRM)
- Dynamic resistance measurement (DRM)
- Synchronized switching
- Coil test
- Minimum voltage test
- Minimum voltage required to operate breaker
- Vibration testing
- Vacuum bottle test
- Primary testing
- Oil test
- SF₆ leakage
- Humidity test
- Air pressure test
- Power factor / Tan Delta / Insulation

First trip test

A good and time effective way to check the condition of a circuit breaker is to document its behaviour at the first open operation after it has been idle for long time. The measurement and connections to the circuit breaker are carried out while it is still in service. All of the connections are made inside the control cabinet.

The biggest benefit of using first trip testing is to test “real world” operating conditions. If the circuit breaker has not operated for years, first trip testing will reveal if the circuit breaker is slower due to problems in the mechanism linkages or coil armatures caused by corrosion or dried grease. With traditional methods, the testing is carried out after the circuit breaker has been taken out of service and has been operated once or even twice.

On a gang operated breaker, (breaker with a common operating mechanism), one coil current is measured and on an IPO (Independent Pole Operated) breaker three coil currents are measured. Analysing the coil current signature gives information of the CB condition. Auxiliary contacts timing can also be measured. Opening times can be measured by monitoring the protection CTs’ secondary current, however, the arcing time will then be included. If there is a parallel current path available the opening times can be more accurately determined since the arcing is minimized. A more advanced approach to first trip is to also measure vibration. This provides detailed information of the status of the circuit breaker. These measurements during first trip are possible with TM1800 and TM1700.

Extra caution must be taken since there are live circuits in the control cabinet and the mechanism is fully charged. The breaker can operate at any time a fault condition occurs.



Contact timing

Main contacts

Definition of time measurements according to IEC	
Opening time	The time interval from the opening release (e.g. coil) is activated to the instant when the arcing contacts have separated at all poles.
Closing time	The time interval from the closing device (e.g. closing coil) is activated to the instant when the arcing contacts touch each other in all poles

Simultaneity within a single phase is important in situations where a number of contacts are connected in series. Here, the breaker becomes a voltage divider when it opens a circuit. If the time differences are too great, the voltage becomes too high across one contact, and the tolerance for most types of breakers is less than 2 ms. The reason is that the multiple breaks together make a voltage divider (in open position). If the time spread is too big it will result in over-voltage on a single contact. Serious damages on the breaking chamber might occur.

The time tolerance for simultaneity between phases is greater for a 3-phase power transmission system running at 50Hz since there is always 3.33 ms between zero crossovers.

Still, the time tolerance is usually specified as less than 2ms, even for such systems. It should also be noted that breakers that perform synchronized switching must meet more stringent requirements in both of the aforesaid situations.

Breaker synchronization (phase vs. phase)

- < 1/4 cycle @ close operation (IEC62271-100)
- < 1/6 cycle @ open operation (IEC62271-100)

Phase synchronization (interrupters inside phase)

- - < 1/8 cycle (IEC62271-100)

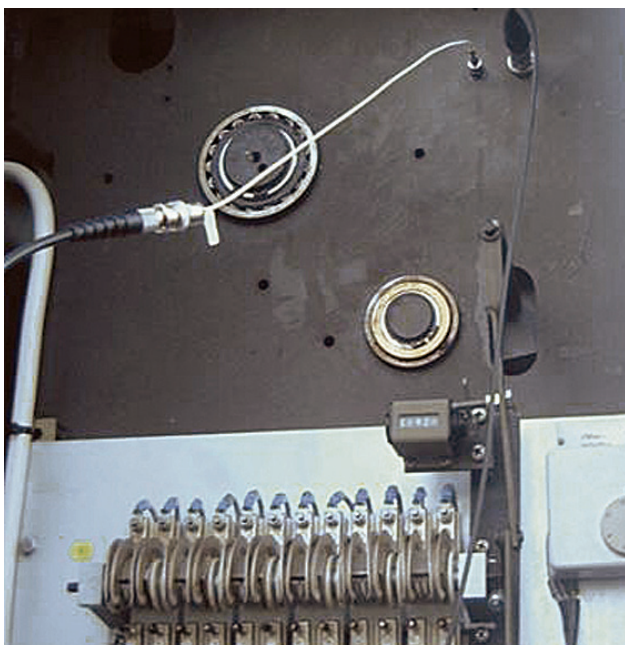

Auxiliary contacts. Accelerometer attached for vibration measurement.

Resistor contacts

The resistor contacts can be of pre or post insertion type. Timing of resistor contacts are made simultaneously with the main contacts but the resistor contacts are only detected while the main contact is open. The resistance value is a good parameter for evaluation.

Auxiliary contact timing

There are no generalized time limits for the time relationships between main and auxiliary contacts, but it is still important to understand and check their operation. The purpose of an auxiliary contact is to close and open a circuit. Such a circuit might enable a closing coil when a breaker is about to perform a closing operation and then open the circuit immediately after the operation starts, thereby preventing coil burnout.

The auxiliary contacts are of three types; a (NO), b (NC) and Wiper (temporary). Type a is following the position of the main contacts and type b is in the opposite position. The Wiper makes a temporary closure during both close and open operation.

Auxiliary contacts are sometimes also used to convey different dynamic properties of the circuit breaker, such as speed and damping. The results from timing these contacts can be used to adjust the circuit breaker.

There are also auxiliary contacts used for interlocking such as spring charge indication, hydraulic pressure, SF₆ density monitor, X/Y-relay, anti-pump relay etc.

Timing of graphite breakers

Conventional timing test methods cannot be applied on circuit breakers having graphite nozzles because they will result in unstable, non repeatable timing values. Instead a DRM (Dynamic Resistance Measurement) has to be performed and the resistance graphs are then evaluated with a tailored algorithm to determine the time reference, which is the transition between graphite/silver and silver/silver on close and between silver/silver and silver/graphite on opening. The software will also compensate for the time offset created by the time it takes for the moving contact to travel the length corresponding to the graphite nozzle length.

Primary injection test

For primary injection testing, high current is injected on the primary side of the current transformer. The entire chain – current transformer, conductors, connection points, relay protection and sometimes circuit breakers as well is covered by the test. The system being tested must be taken out of service during primary injection testing. Testing is usually conducted in connection with commissioning.

The only way to verify that a direct-acting low voltage circuit breaker operates properly is to inject a high current.

Motion

A high-voltage breaker is designed to interrupt short-circuit current in a controlled manner. This puts great demands on the mechanical performance of all components in the interrupter chamber as well as the operating mechanism. It has to operate at a specific speed in order to build up adequate pressure to allow for cooling stream of air, oil or gas (depending on the type of breaker) to extinguish the arc that is generated after the contact separation until the next zero-crossing. It is important to interrupt the current to prevent a re-strike. This is accomplished by making sure that the contacts move apart far enough from each other before the moving contact has entered the so-called damping zone.

The distance throughout which the breaker's electric arc must be extinguished is usually called the arcing zone. From the motion curve, a velocity or acceleration curve can be calculated in order to reveal even marginal changes that may have taken place in the breaker mechanics.

The contact travel motion is captured by connecting a travel transducer on the moving part of the operating mechanism. The transducer provides an analogue voltage relative to the movement of the contact. The motion is presented as a curve where distance vs. time allows for further analysis.

From the motion curve, a velocity or acceleration curve can be calculated in order to reveal changes in the breaker mechanics that may affect the breakers operation.

Travel

The travel trace indicates the instantaneous position of the circuit breaker contacts during an operation. This gives important information such as total travel, overtravel, rebound, undertravel, contact wipe or penetration of moving-contact or operating-rod position at the time of close or open, and anomalies which are evident from the trace.

Speed

Speed is calculated between two points on this motion curve. The upper point is defined as a distance in length, degrees or percentage of movement from a) the breaker's closed or open position, or b) the contact-closure or contact-separation point. The lower point is determined based on the upper point. It can either be a distance below the upper point or a time before the upper point. The time that elapses between these two points ranges from 10 to 20 ms, which corresponds to 1-2 zero-crossovers.

The single most important benefit derived from the instantaneous velocity and acceleration curves is the insight that they provide into the forces involved during the operation of a circuit breaker.

Acceleration

Average acceleration can be calculated from the velocity trace.

Damping

Damping is an important parameter to monitor and test as the stored energy an operating mechanism use to open and close a circuit breaker is considerable. The powerful mechanical stress can easily damage the breaker and/or reduce the breaker's useful life. The damping of opening operations is usually measured as a second speed, but it can also be based on the time that elapses between two points just above the breaker's open position.

Static resistance measurement (SRM)

Test is conducted by injecting DC current through the breaker main contact system when circuit breaker is closed. By measuring the voltage drop the resistance can be calculated. The value of the main contact resistance reflects the condition of the conducting parts.

A static resistance value provides a reference value for all types of electrical contacts and joints. IEC56 states that this type of resistance is to be measured using a current ranging between 50 A and the breaker's nominal current. ANSIC 37.09 specifies a minimum test current of 100 A. Other international and national standards set forth similar guidelines in order to eliminate the risk of obtaining erroneously high values if the test current is too low. In some cases, heat generated by a high test current disperses any contact grease remnants or other impurities found on contact surfaces (resulting from numerous high-current breaking operations).

When the circuit breaker is in bad shape the values will change dramatically from the values from factory.

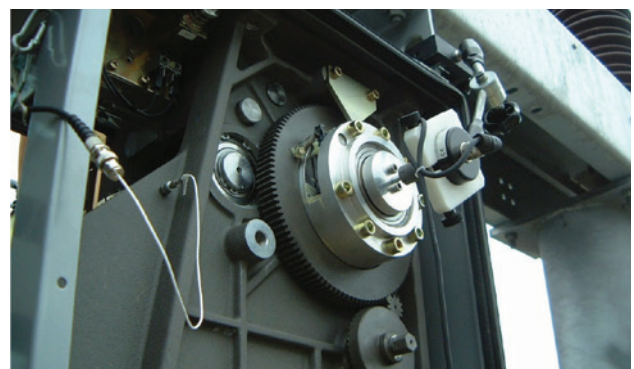

Circuit breaker operating mechanism with rotary motion transducer and accelerometer (for vibration measurement).

Motion diagram and timing graphs for a close-open operation

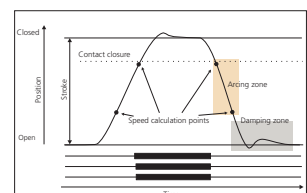

ANSI writes about 200% increase of resistance over the max value specified from factory.

Dynamic resistance measurement (DRM)

Tests are conducted by injecting DC current through the breaker main contact and measuring the voltage drop and current while the breaker is operated. The breaker analyser then calculates and plots resistance as a function of time. If contact movement is recorded simultaneously, you can read the resistance at each contact position. This method is used for contact diagnosis, and in certain cases it is also used to measure times.

With DRM measurement the arcing contact length can be reliably estimated. The only real alternative in finding the length of the arcing contact is dismantling the circuit breaker. In SF₆ breakers the arcing contact is commonly made of Wolfram (tungsten). This contact is burned off and becomes shorter for each interruption of load current.

A reliable DRM interpretation requires high test current and a circuit breaker analyser with good measurement resolution.

Synchronized (Controlled) switching

In order to test function of a controlled switching device one or more currents from current transformers and reference voltage from voltage transformer as well as controller output signals are recorded during issuing Open or Close command. Specific setups depend on test instrumentation, available current and voltage sources and installed switching controller. Typical controlled switching setup using controller where poles are controlled separately is shown below.

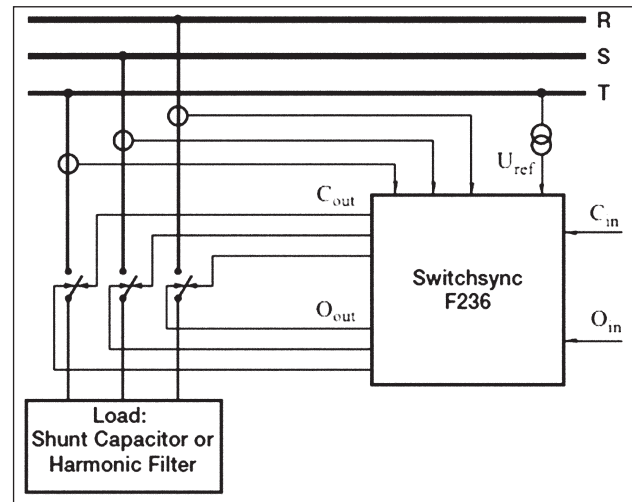

- Cin Close command
- Oin Open command
- Uref Reference voltage
- Cout Close commands individual for each phase
- Oout Open commands individual for each phase

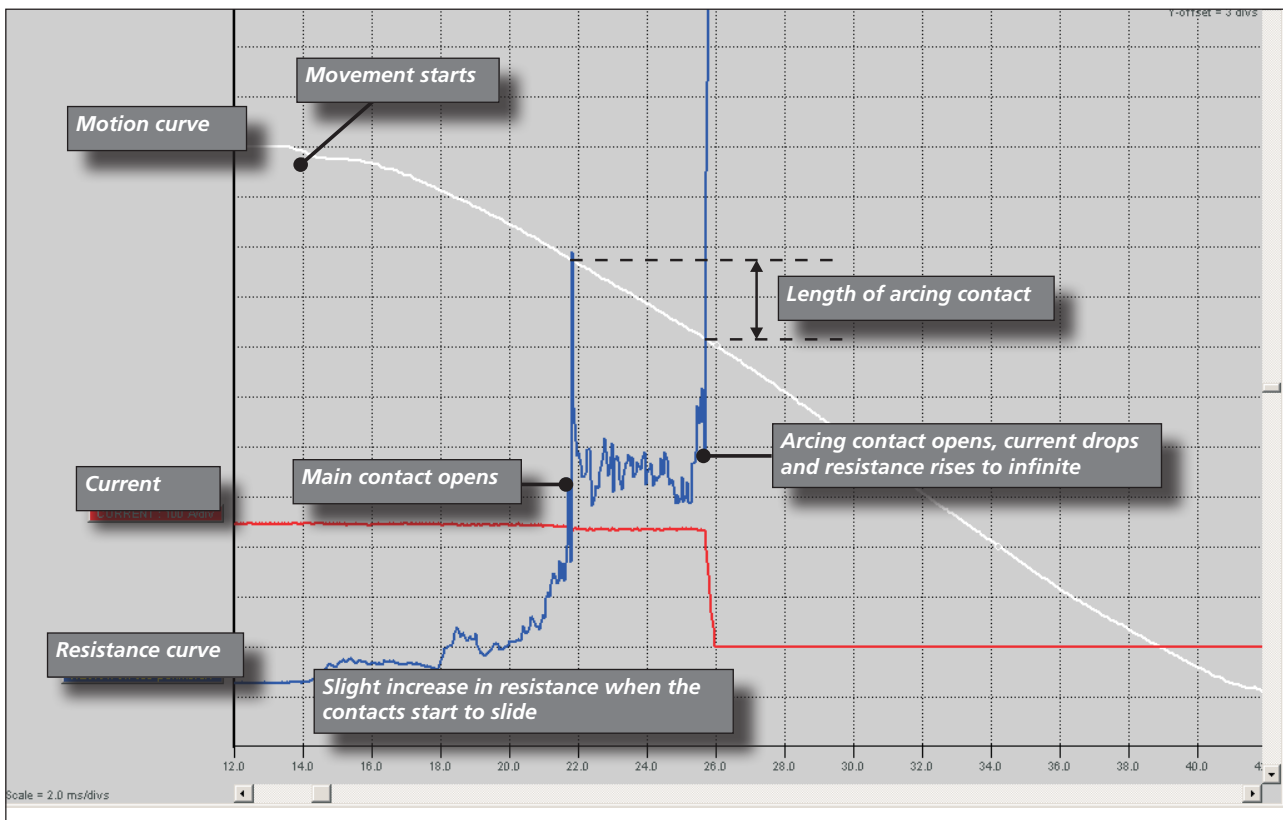

DRM is a reliable method to estimate the length/wear of the arcing contact. The SDRM202 provides high current and the TM1800 gives an accurate measurement with very good resolution. Besides, it is possible to use DualGround testing.

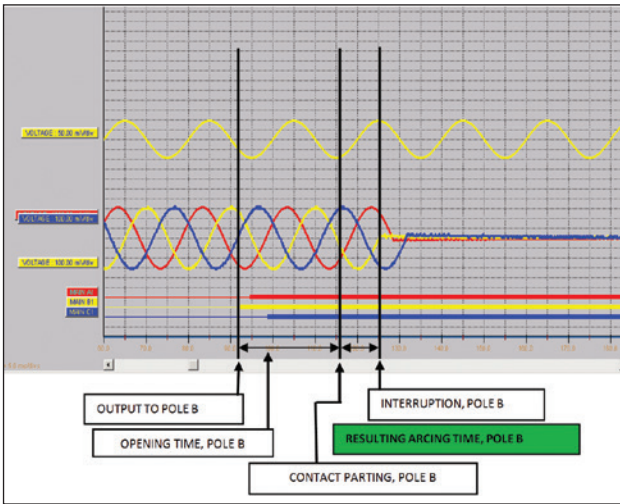

An example of results from Open operation.

Coil test

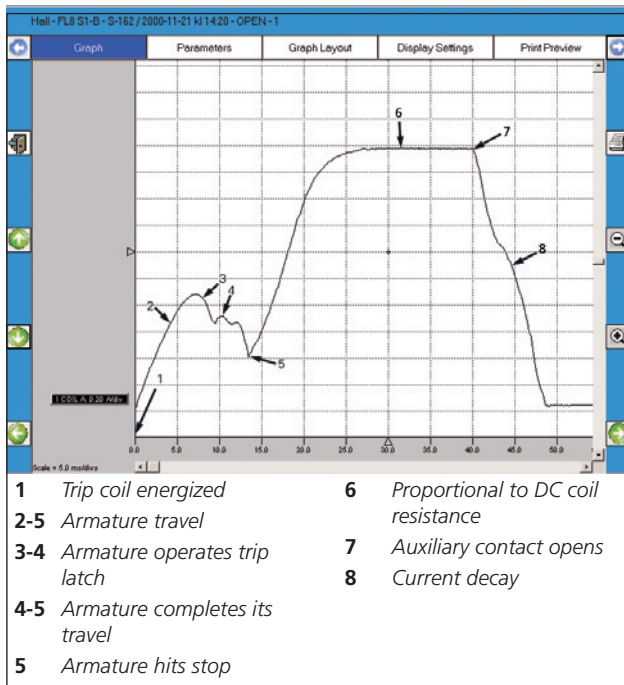

Example of coil current on circuit breaker

When a trip coil is first energized [1], current flows through its windings. The magnetic lines of force in the coil magnetize the iron core of the armature, in effect inducing a force in the armature. The current flowing through the trip coil increases to the point where the force exerted on the armature is sufficient to overcome forces, combined gravitational and friction, which may be exerted, pulling [2] it through the trip coil core.

The magnitude of the initial current [1-2] is proportional to the energy required to move the armature from its initial rest position. The movement of the iron core through the trip coil generates an electromagnetic force in the coil that in turn has an effect on the current flowing through it. The rate of rise of current depends on the change in the inductance of the coil.

The armature operates the trip latch [3-4], which in turn collapses the trip mechanism [4-5]. The anomaly at [4] is the point where the armature momentarily stops when contact is made with the prop. More energy is required for the armature to resume motion and overcome the additional loading of the prop. The anomaly may be caused by degradation of the prop bearings, lubrication, changes in temperature, excessive opening spring force or mechanism adjustment. The armature completes its travel [4-5] and hits a stop [5].

Of interest is the curve [4-5]. As the armature moves from the point where the trip mechanism is unlatched [4] to the stop [5] the inductance of the coil changes. The curve is an indication of the speed of the armature. The steeper the curve the faster the armature is moving.

After the armature has completed its travel and has hit the stop [5], there is a change in current signature.

The magnitude of the current [7] is dependent on the DC resistance of the coil.

The 'a' contact opens [8] to de-energize the trip coil and the current decays to zero.

The interpretation of circuit breaker operating coil signatures may provide information about the condition of the latching systems.

Current

When you apply a voltage across a coil, the current curve first shows a straight transition whose rate of rise depends on the coil's electrical characteristic and the supply voltage. When the coil armature (which actuates the latch on the operating mechanism's energy package) starts to move, the electrical relationship changes and the coil current drops.

The peak value of the first, lower current peak is related to the fully saturated coil current (max current), and this relationship gives an indication of the spread to the lowest tripping voltage. If the coil were to reach its maximum current before the armature and latch start to move, the breaker would not be tripped. It is important to note, however, that the relationship between the two current peaks varies, particularly with temperature. This also applies to the lowest tripping voltage.

Coil currents can be measured on a routine basis to detect potential mechanical and/or electrical problems in actuating coils well in advance of their emergence as actual faults.

Voltage

In some cases it is also of interest to measure DC voltage sagging during coil operation. The voltage to the coil will vary during operation. This change will influence the coil current, the armature release time and finally the contact timing.

Minimum voltage test

This test is often neglected even though it is specified and recommended in international standards. The test objective is to make sure that the breaker can operate at the lowest voltage level provided by the station battery when the breaker has to operate during a power outage. The test is performed by applying the lowest specified operating voltage and verify that the breaker operates within specified operation parameters. Standard test voltage is 85% and 70% of nominal voltage for close and open respectively.

Minimum voltage required to operate breaker

This test should not be confused with the above described. In this test you determine the minimum voltage at which the breaker is able to operate. It is a measure of how much force that is needed to move the coil armature. In this test you are not interested in contact timing parameters, only whether the breaker operates or not. You start on a low voltage sending a control pulse to the breaker. If not operating you increase the voltage with say 5 V and try again, and so on. Once the breaker has operated you note the voltage at which operation occurred. Next time maintenance is done you can compare your results with the old test value to determine changes.

Vibration testing

Vibration testing is based on the premise that all mechanical movements in an equipment produce sounds and/or vibrations, and that by measuring them and comparing the result with the results of previous tests (known data), the condition of the equipment in question can be evaluated.

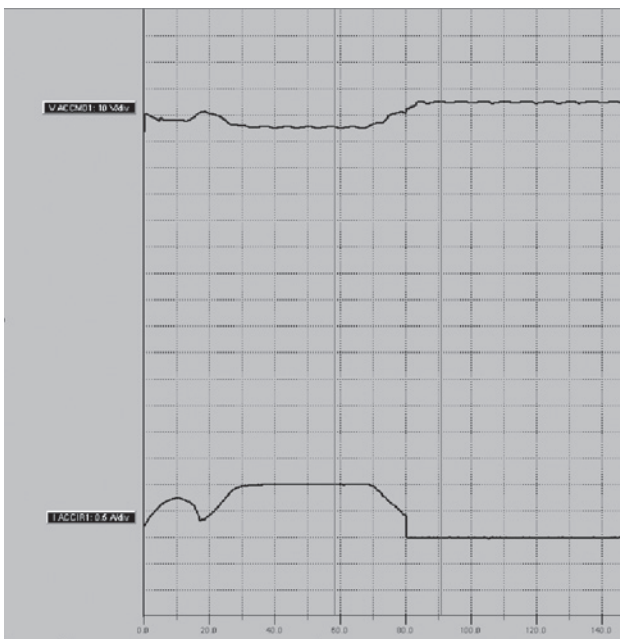

The figure shows trip coil current and DC voltage sagging in an open operation. The open circuit voltage is 128 V and the voltage sag is about 14 V at maximum trip current 11 A. These are normal values and do not indicate any malfunctions in the DC operating voltage circuitry.

The easiest factor to measure is the total vibration level. If it exceeds a given value, the equipment is deemed to be in the fault or risk zone.

For all types of vibration testing, a reference level must have been previously measured on equipment known to be fault free. All measurements on the equipment tested are then related to this reference signature in order to determine whether or not the measured vibration level is “normal” or that it indicates the presence of faults.

Vibration testing on circuit breaker

Vibration analysis is a non-invasive method using an acceleration sensor without moving parts. The breaker can stay in service during the test. An Open-Close operation is all that is required for the measurement. The first operation can be different compared to the second and third because of corrosion and other metal to metal contact issues. Vibration is an excellent method to capture the first operation after long time in the same position.

The analysis compares the vibration time series with earlier taken reference. The vibration method detects faults that can hardly be indicated with conventional methods. However, if conventional data such as contact time, travel curve, coil current and voltage are available in addition to the vibration data even more precise condition assessment is possible. The vibration data is stored together with available conventional data.

The vibration method is published in CIGRÉ and IEEE® papers. Since about 15 years is it utilized in the industry for testing all kind of breakers from transmission to industrial sites. The method was first established on the Scandinavian market. Vibration can be performed under very safe manners for the test technician as both sides can be grounded throughout the test. Also less climbing is required since no access to the breaker contact system is needed. The acceleration sensor is easily mounted on the breaker.

One or more accelerometers are attached to the breaker poles and operating mechanism. Vibration signals from the accelerometers proceed via a signal conditioning unit that incorporates an amplifier and filter to the Breaker Analyser System TM1800 where they are recorded during breaker operation. The directly recorded vibration signals can be analysed in the CABA Win software, together with time, motion and coil current data.

A sophisticated procedure known as Dynamic Time Warping (DTW) is used for further analysis. DTW compares vibration signals with reference signature obtained (preferably) from a previous test conducted on the very same breaker. Comparisons with the results of tests conducted on other breakers of the same type can be used in the initial phase of a series of tests. Comparison results are presented on a time-time diagram that shows time deviations and also on a deviation diagram that reveals differences in frequency content and amplitude.

All test data and analysis data can be reported along with other data such as motion and speed. The overall results provide a more detailed picture of breaker condition than has heretofore been available.

DTW vibration analysis is available in a separate program module that can be purchased as an optional add-on for CABA Win. This type of measurement requires a high sampling rate and a broad dynamic range. The TM1800 uses 16-bit resolution and 40 kHz sampling rate. Together with a specially designed Signal Conditioning Amplifier SCA600, the TM1800 enables you to measure vibrations with frequencies ranging up to 15 kHz.

Vacuum bottle test

The vacuum bottle in the vacuum circuit breaker is tested with high voltage AC or DC to check that the integrity of the vacuum is intact. The electrical resistance of the vacuum in a breaker is identical in behaviour for AC and DC. The main difference in using DC vs. AC is that AC also is sensitive to the capacitance of the breaker. The DC (resistive) current component is 100 to 1000 times lower in magnitude than the AC (capacitive) current component, depending on the individual bottle capacitance and therefore difficult to distinguish when testing using AC. As a result AC requires much heavier equipment for testing compared to DC test instruments.

Both the DC and the AC methods are detailed in standards; ANSI/IEEE 37.20.2-1987, IEC 694 or ANSI C37.06.

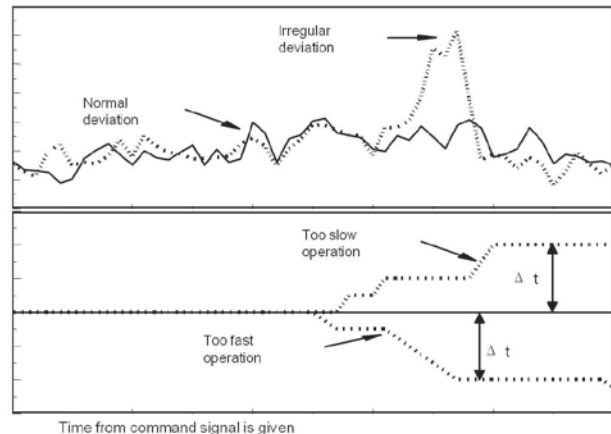

Deviation between test and reference signatures. In this picture you can easily discern deviations that are beginning to appear and trace their origins

SF₆ leakage

SF₆ leakage is one of the most common problems with circuit breakers. The leakage can occur in any part of the breaker where two parts are joined together such as valve fittings, bushings and flanges but in rare cases it can leak straight through the aluminium as a result of poor casting.

These leaks can be found by using gas leak detectors (sniffers) or thermal imaging.

Humidity test

As humidity can cause corrosion and flashovers inside a breaker, it is important to verify that the moisture content inside a SF₆ breaker is kept to a minimum. This can be done by venting a small amount of SF₆ gas from the breaker through a moisture analyser which will tell you the moisture of the gas.

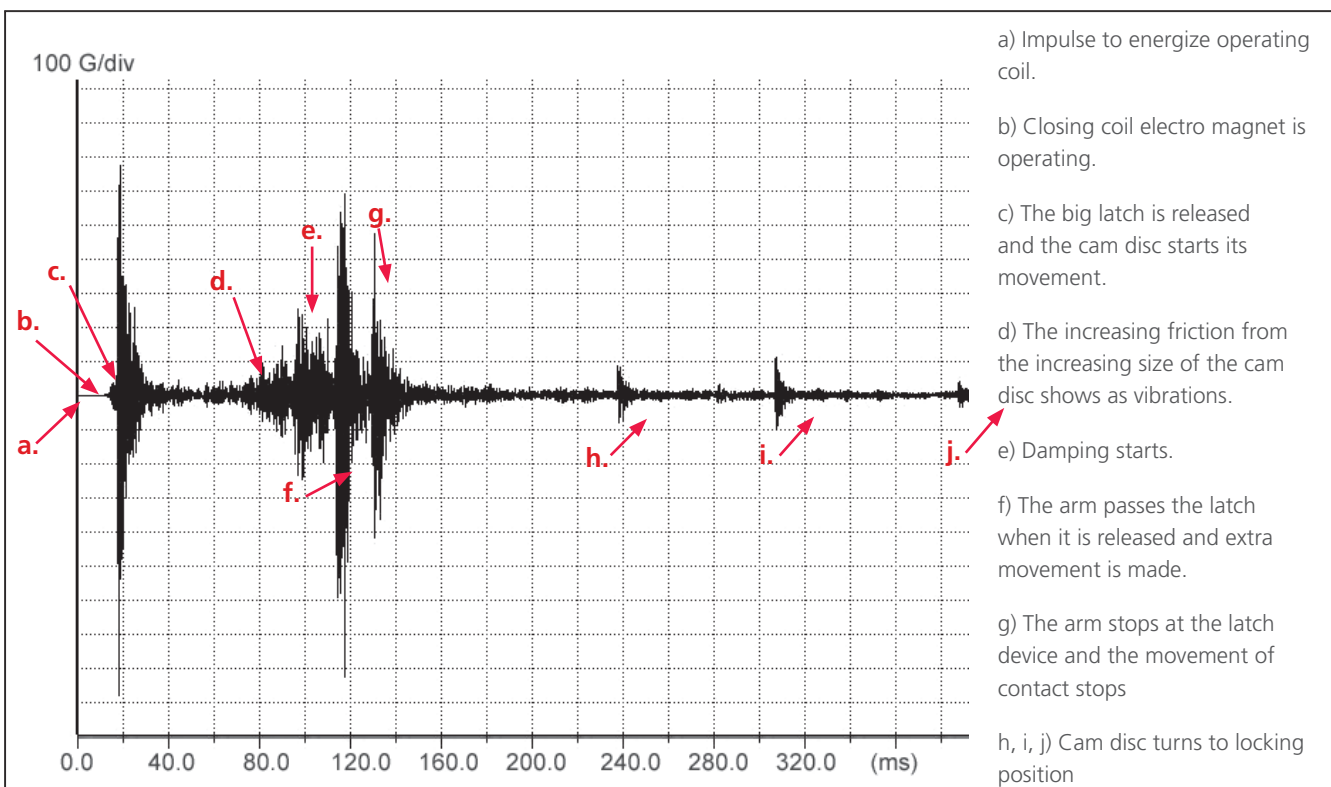

A characteristic vibration signal recorded at the operating mechanism at a close operation



Air pressure test

Air pressure testing is carried out on air-blast breakers. Pressure level, pressure drop rate and air flow are measured during various operations. The blocking pressure that will block the breaker in the event of very low pressure can also be measured.

Mounting of motion transducer

For many years, breaker contact motion (travel) has been considered one of the most important parameters for checking a breaker's interrupting capacity. Some types of breakers are accompanied by instructions that explain how to mount a motion transducer and some are not. There is, therefore, a need for a few simple guidelines for selecting the right type of transducer and the location on the breaker where measurements are to be taken.

The relation between the mechanical movement of the main contact and the transducer data output can be proportional 1:1, 1:x or non-linear. Ideally, a linear transducer should be used when the main contact moves along a straight path. The transducer should be attached firmly enough to eliminate play and aligned in the direction taken by the operating mechanism rod.

Another option is to use a rotary transducer connected to a shaft end on the gearing located beneath the breaking pole. Using a transducer fitting is by far the fastest way to attach a motion transducer. The movement in the point selected for attaching the sensor may not be proportional to the movement of the main contact. To solve this problem, a conversion table can be prepared. This conversion table will enable the PC software to present the contact's motion and speed. Two options are available:

- 1. Find out the geometrical transfer function between the transducer attachment point and the moving contact. A table, with degrees in the left column and distance in the right column, can then be generated from this function.**
- 2. Perform a measurement with one linear transducer attached to the moving contact and one rotary transducer attached to the most practical point. The position of the linear transducers, at each degree turned on the rotary transducer, is preferable read during a "slow close" operation. However, if this is not possible a normal operation can be used and then the most critical one should be selected, e.g. open.**

If it proves impossible to obtain verified limit and calculation points for the breaker's closing and opening speeds, an alternative is to select a suitable attachment point and produce a "footprint" that can be used as a reference for the breaker in question.

At the very least, this will enable any departures from present conditions to be detected. Good universal attachment fittings are available for transducers. One is designated as a rotary transducer kit. If a particular type of breaker is tested frequently, it may be advisable to obtain a made-to-order tool that can be used to attach the transducer at the selected point. Don't forget to use a flexible coupling between the rotary transducer and the breaker shaft since any change in the position of the shaft that occurs over time can damage the transducer.

Test equipment

Test equipment for CB-testing includes one ore more of the following:

- **Micro-ohmmeters**
- **Breaker analysers**
- **Power supplies**
- **Vacuum testers**
- **High current sources**
- **Software – including capability to do the following**
 - Set user defined parameters
 - Create databases
 - Generate reports
 - Analyse data
 - Create graphical presentations

Product selection guide

Below is a selection guide for the Megger circuit breaker analyzers.

Measurement entity	Circuit breaker configuration	EGIL Model / Config	TM1700 Model	TM1800 Modules / Configuration
Main contact timing	1 break / phase	EGIL Basic	All TM1700	1 Timing M/R
	2 break / phase	–	All TM1700	1 Timing M/R
	≥ 4 break / phase	–	All TM1700 4)	2 - 7 Timing M/R
Main and PIR contact timing	1 break / phase	EGIL Basic	All TM1700	1 Timing M/R
	2 break / phase	–	All TM1700	1 Timing M/R
	≥ 4 break / phase	–	All TM1700 4)	2 -7 Timing M/R
Coil current	1 operating mech.	EGIL Basic	All TM1700	1 Control
	3 operating mech.	–	TM1720/50/60	2 Control or 1 Control + 1 Analog + 3 ext. current clamps
Motion	1 operating mech.	EGIL Motion EGIL SDRM	All TM1700 5)	1 Analog or 1 Digital
	3 operating mech.	–		1 Control 1) or 1 Timing AUX
Auxiliary contact timing	1 operating mech.	EGIL Basic	TM1710 1) TM1720/50/60	1 Control 1) or 1 Timing AUX
	3 operating mech.	–	TM1720/50/60	2 Control 1) or 1 Control + 1 Timing AUX
	≥ 3 aux / phase	–	TM1720/50/60	1 Control 1) and 1 Timing AUX or 2 timing aux
SRM 3)	Any	EGIL SDRM	All TM1700	1 Timing M/R + 1 Analog
DRM 3)	Any	EGIL SDRM		1 Timing M/R + 1 Analog + 1 Digital 2)
1) 52a/b timing only				
2) If digital motion transducer				
3) SDRM201/202 accessory required				
4) Phase by phase and max 6 breaks / phase				
5) With 6 digital transducers or option with 3 analog channels.				

Good to know about error sources

Capacitive coupling

Capacitive coupled current is the current that leaks through the stray capacitances formed by overhead live lines as one electrode, air or other insulation medium as dielectricum and a device under test or ground as the other electrode. If the device under test is floating, i.e. not connected to earth, the voltage level of the device could reach double digit values in kV due to capacitive voltage division, live line/device, device/ground.

Capacitive coupled currents can in worst case reach values up to 20 mA AC in HV substations. The current level depends on the distance from the device under test to overhead live lines, the length of the live line that the device under test is exposed to and air humidity. The capacitive coupled current can be seen as a constant current source.

When timing a circuit breaker in a conventional way (not DualGround) the capacitive coupled current will pass through the breaker's main contacts and resistor contacts (if existing) and interfere with the test current generated by the test equipment. This is particularly crucial when timing resistor contacts and measuring the value of the pre-insertion resistors, since the interference current could be in the same range as the test current therefore making big impact of the result. The interference current is an AC that will contribute to the test current half of the period and the opposite the other half making it difficult to compensate for even if you would know the value. Not considering the effect of the interference current could result in resistor contact timing errors up to plus minus a half period.

When measuring pre-insertion resistor values the capacitive coupled current passing through the test object superimposes an interference current resulting in erroneous reading of voltage drop. Since resistor contacts usually are engaged only for a short time (a couple of milliseconds) there is no possibility to determine the amount of interference current by looking on the periodical changes (50/60 Hz). Suppressing these frequencies by means of filters is not feasibly due to the propagation delays the filters would introduce. Measuring without interference suppression will subsequently result in inaccurate, non-repeatable results depending on where in the cycle the AC interference current happen to be at the instant of PIR value measurement. The measurement error will be proportional as: Peak interference current divided by Test current. Example: If the test current is 50 mA through the PIR and the interference current is 10 mA peak the error will be $10 / 50 = 20\%$. (The test current should be calculated as the test voltage divided with the PIR value.)

To minimize the size of the capacitive coupled current, the side of the test object that has the longest exposed part to live overhead lines should be grounded, if there is a choice and if single ground is applied. For DualGround capacitive coupled current is not a problem.

TM1800 uses a patented active interference suppression that neglects the influence of the interference current.

Inductive coupling

Inductive coupled currents are created by the alternating magnetic field that a conductive loop is exposed to. Examples of such a loop could be test cables or a test object grounded in both ends. The area of the loop, the magnetic field and the resistance in the loop determines the value of the induced current. The voltages created by induction is normally very low, partitions of a Volt, but the current can reach double digit values in Amperes AC.

This current can interfere with Static and Dynamic resistance measurement and affect the measurement value. As the inductive coupled current is an AC it will contribute to the test current during one half of a period and the opposite during the other half introducing an error in the voltage drop reading. To minimize the influence of induced currents cable loops should be minimized e.g. by twisting cables together as far as possible.

Disturbances

Instruments used in switchgear environment are in general well protected against disturbances but have of course limitations of what they can withstand. They need to have proper supply from AC system or batteries.

To avoid unnecessary disturbances instruments should in general be grounded and object should be disconnected and also grounded on at least one side.

When the auxiliary contact breaks up the coil circuit a voltage spike is created over the contact. The spike has high frequency contents that quite easily can be propagated to measurement circuits resulting in disturbances of the test result. To avoid cross talk between control circuits and measurement circuits, cables for corresponding purpose should be separated from each other.

Temperature

Temperature can affect both the measuring instruments and the measured object and hence the result. Especially low temperatures may cause the mechanical parts move more slowly because the oil and grease becomes more viscous.

At low temperatures the pressure of the interrupting medium (SF_6 , SF_6/N_2 or SF_6/CF_4 blend) decreases, which could affect the contact timing and operation speed of the moving contact.

One should therefore make measurements at times with very similar temperature as possible if you want to compare the readings. If this is not possible at least a temperature note should be made and stored along with the test data.

Voltage supply

When supplying the breaker operating coils you need a stable voltage supply that is capable of delivering the current that the coils require. If you use a DC supply it should be one with low ripple.

It is also important that the supply has a floating output, isolated from ground, not only for personal safety reasons, but also because the station's auxiliary voltage circuitry might be equipped with a ground fault indication system.

Measurement of control voltage

It is of big importance to measure the control voltage at each recording since both timing results and coil current traces are depending on the voltage that is applied. In order to make a fair comparison between two tests it is crucial to verify that the control voltages are equal.

Excluding the control voltage parameter could complicate the backtracking of the reason for an outlier when making trend analysis.

Connections, leads and clamps

Make sure of a good electrical contact to the test object. When there is paint or corrosion on the object, you must remove this to get good connection. Make sure you connect as close as possible to the measurement point, especially during resistance measurements.

Circuit breaker operation is very powerful and vibrations can cause clamps to lose connection with object during measurement. This can cause odd results and "false bounces" caused by the bad connection.

When using incremental transducers avoid long cables; the signal can be damped. Generally, keep cables short and when needed twist them to avoid induction from magnetic fields. Keep different types of test cables away from each other. Make sure to use the right cable intended for the specific measurement.

Some cables have grounded screens to reduce disturbances. These shall be used for measurements of analogue entities whereas unshielded cables is to be used for contact timing.

At DualGround testing with DCM the test cables shall not be moved after tuning the circuit. If the position of the cables are changed a new tuning has to be performed when the circuit breaker is in closed position.

Transducer and flex coupling tolerances

Avoid endpoints at linear transducers since the electrical stroke might be shorter than the mechanical stroke. Transducer accuracy is influencing the result of motion, hence it is important to use a transducer with good linearity and dynamic properties.

A flex coupling of good quality that protects the transducer from mechanical damage and transfers the motion without distorting it is highly recommended.

The electrical angular span of a rotary analogue transducer is usually less than 360° causing a gap of approximately 3° giving undefined values. This gap should be avoided during measurement.

Sampling frequency

Sampling frequency is the number of samples the measurement channel makes per second. Measuring with too low sampling frequency can result in that important information e.g. contact bounces, never gets recorded. It is recommended to use at least 10 kHz for timing measurements, 20 kHz for Dynamic Resistance Measurements and 40 kHz for vibration measurements.

Inaccuracy

The test should be made with instrument with low inaccuracy. The total fault depends not only on instruments channels specifications, but also on transducers, cabling and accessories. During motion measurements the faults are influenced by cabling, flex couplers, transducer inaccuracy, mounting of transducer and (if used) conversion tables. Current readings are influenced by disturbance in the current clamp, cabling, transducer offset and current transformer specification.

Temperature can influence instruments and accessories specifications.

To minimize the error caused by the test instrument the calibration intervals recommended by the manufacturer should be obeyed.

Interpretation of the test results

Effective circuit breaker maintenance requires well-organized, accurate testing. The ability to accurately compare circuit breaker tests with previous test results is essential. It is, therefore, imperative to conduct tests in exactly the same way and under the same conditions as those conducted earlier. Comparison can then provide a clear picture of any deviations and changes, thereby indicating whether or not the circuit breaker should be kept in operation or taken out of service for further investigation.

Comprehensive, accurate testing also requires analytical tools and efficient reporting. It must be possible to validate test results in detail and then easily compare them with other test results.

The test data are valuable information that must be safely stored, including data backup on media that can be used for years to come.

Failure mode analysis

The charts below indicates some typical failure modes of timing, voltage and current measurements on HV Breakers and looks at the various mechanical areas that could cause an out-of-tolerance condition.

Timing measurements				
Close Time	Open Time	Damping Time	Charging Motor	Possible cause of failure condition
Faster/ Slower	Normal	Normal	Normal	Change in characteristic of the closing system. Latching system is binding.
Faster	Normal	Normal	Normal	Spring charging system used for closing is defective.
Slower	Normal	Normal	Normal	
Normal	Slower	Normal	Normal	Change in characteristic of the closing system. Latching system is binding.
Faster	Slower	Normal/ Slower	Normal/ Slower	Reduced force exerted by opening springs. One of the opening springs is broken.
Slower	Slower	Normal/ Slower	Normal/ Slower	Increased friction throughout the entire breaker caused by (for example) corrosion in the linkage system.
Normal	Faster	Normal	Normal	Malfunctioning puffer system or extremely low SF6- pressure.
Normal	Normal	Faster	Faster	Damaged opening damper. Not enough oil in the dashpot.
Normal	Normal	Slower	Slower	Damaged opening damper. Increased friction in the dashpot

CB operating system	
Tested parameter	Result
Coil current	Varies with coil resistance and control voltage
Control voltage	Increased voltage drop indicates increased resistance of the coil supply cables. ■ Must be measured in order to obtain traceability of coil current measurements and timing measurements
Coil resistance	A change could indicate a burned coil or a short circuit between winding turns. ■ Can be calculated from control voltage and peak current
Armature stop time	Increased time indicates increased mechanical resistance in latch system or coil armature
Armature start current	Increased current indicates increased mechanical resistance in coil armature ■ Gives an indication of the lowest operation voltage (coil pick up).
Max motor current	Varies with winding resistance, supply voltage and applied force. ■ Start current not considered.
Motor voltage	Increased voltage drop indicates increased resistance in the motor supply cables
Spring charge motor start time	Closing time of auxiliary contact for the spring charge motor
Spring charge motor stop time	Increased time shows e.g. higher mechanical friction

<p>How can I get more current out of my primary injection test set?</p>	<p>Twist the cables to reduce inductance</p> <p>Keep the cables as short as possible</p> <p>Use thicker cables or more cables in parallel</p> <p>Make sure that the contact surfaces are clean</p> <p>Confirm that binding posts and connection clamps are firmly tightened</p>
<p>What kind of motion transducer should I use for a circuit breaker?</p>	<p>Follow the CB manufacturer's recommendations</p> <p>The general recommendation is to use rotary transducer attach and to attach it to a rotating point in mechanism.</p> <p>For live tank breakers you generally use a rotary transducer but for dead tank breakers and bulk oil circuit breakers you generally use a linear transducer.</p>
<p>Where should I attach the motion transducer?</p>	<p>Follow the CB manufacturer's recommendations</p> <p>If the above is missing you should choose a point in which the motion of the moving contact, as close as possible, is reflected. This point could have a linear or a rotary movement and it could be located in the operating mechanism or in a gear case close to the breaker pole</p>
<p>Why should I test the CB with both sides grounded?</p>	<p>When the CB is grounded just in one side, the opposite side will become ungrounded when the CB is opened. This will expose the test engineer to danger caused by capacitive coupled currents, lightning or unintentional energizing of the test object.</p> <p>National, international and local standards and regulations states that all metallic parts in a substation should be connected to ground.</p>
<p>How do I get conversion tables for my circuit breaker?</p>	<ul style="list-style-type: none"> - Contact manufacturer of your circuit breaker - Find out the geometric transfer function between the point of transducer attachment and the moving contact and create your own table. - Make a reference measurement with one transducer attached on the moving contact and one in the desired transducer attachment point. From the result of the reference measurement a table can be created.
<p>I don't have data from manufacturer on my circuit breaker. How can I analyze my object?</p>	<ul style="list-style-type: none"> - Make a reference measurement (footprint) of the CB when it is new and use this to compare with for the succeeding tests. - Use default settings for speed calculation points - Compare results with other circuit breakers of the same type

Megger CB testing products

– overview

Circuit breaker analysers

TM1800

The TM1800™ is the instrument platform for circuit breaker maintenance, based on more than 20 years' experience of over 4,000 delivered breaker analysers. The modular construction makes it possible to configure the TM1800 for measurements on all known types of circuit breakers in operation on the world market. The robust design contains powerful technology that streamlines circuit breaker testing. Sophisticated measurement modules enable great time savings as many parameters can be measured simultaneously, eliminating the need for new setup each time. The patented DualGround™ testing using the new DCM module makes the testing safe and time saving, by keeping the circuit breaker grounded on both sides throughout the test. The DCM module uses a measuring technology called Dynamic Capacitive Measurement. The Timing of Main and Resistance contacts uses patented active interference suppression to obtain correct timing and accurate PIR (Pre-Insertion Resistor) values in high voltage substations.



TM1700-series

The latest instrument in the TM-family have used much of the technology from the top of the line version TM1800. TM1700 comes in four models starting from PC-remote controlled to fully stand-alone. One important news is the test wizard that quickly guides the operator through the test set-up.



EGIL

EGIL is designed specifically for medium-voltage breakers having one main contact per phase. Main contacts and parallel contacts having pre-insertion resistors are recorded and displayed simultaneously. Coil currents and two auxiliary contacts are also measured as standard. EGIL can be equipped with an analogue channel e.g. for motion measurement and a USB port for communication with the CABA computer program. EGIL with the SDRM option together with the SDRM accessory enables static and dynamic resistance measurements.



EGIL 200

The EGIL200 has been developed in response to user demand for an affordable mid-range circuit breaker analyser that is fast and easy to use. The new EGIL 200 from Megger, delivers dependable results with a minimum of user intervention. Ideally suited for testing high and medium voltage circuit breakers in substation and industrial applications, offering a wide range of functions, including all of the standard measurements specified in the IEEE C37 and IEC 62271 standards.



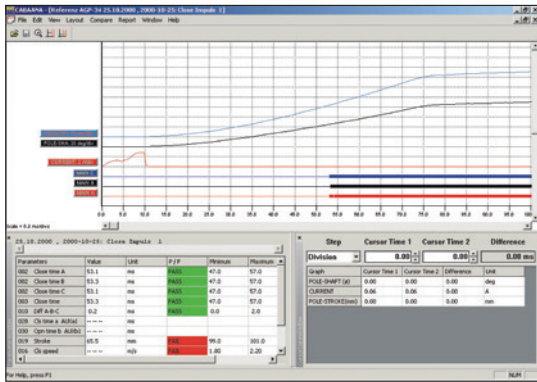

Breaker Analyser Program CABA Win

After connecting your breaker analyser to a personal computer (PC), you can use CABA to speed up testing and improve reliability. CABA can be used with the TM1800, TM1700 and EGIL series of instruments. Results are presented on the display both graphically and in table form after each breaker operation so that you can make comparisons with limit values and previous test results. Simple procedures enable you to create individual test plans tailored to individual breakers. Time-saving conversion tables simplify the task of connecting and linking transducers to the breaker. Reports created in your own format can be obtained easily using standard field linking functions.



VIDAR

VIDAR tests vacuum in circuit breaker chambers using DC voltage. When AC is used, the capacitive component of the current flowing through the chamber must be tested. With DC, this is eliminated. The resistive component of the leakage current is very small compared with the capacitive component, because of the high dielectric strength of the chamber. The DC flashover voltage is equal to the peak AC voltage. Testing can be completed in a few minutes.

Auxiliary equipment



B10E

Supplies power conveniently to breaker coils and spring-charging motors. Since this power is unaffected by load and virtually ripple-free, it's ideal for minimum trip-voltage tests.



SDRM202

The SDRM202 is an accessory for TM1800, TM1700 and EGIL with SDRM option.

The SDRM202 is intended to use for both static and dynamic resistance measurements (SRM and DRM) on high voltage circuit breakers or other low resistive devices. Used together with TM1800, TM1700 or EGIL the current and also the voltage-drop across the circuit breaker contacts are measured. The measuring unit can thus calculate the resistance as a function of time.

Micro-ohmmeters

The extensive range of products is designed to use high currents for both static and dynamic resistance measurement. Here is a part of the portfolio of micro-ohmmeters.

MJÖLNER 200 and MJÖLNER 600

MJÖLNER 600 is designed to measure the resistance of circuit breaker contacts, bus-bar joints, contact elements in bus-bars and other high-current links. The product has been designed with safety, ease of use and versatility in mind. With MJÖLNER 600 it is possible to make measurements according to the DualGround™ method. This means that the test object will be grounded on both sides throughout the test giving a safer, faster and easier workflow.



MOM2

The ruggedness and lightweight, 1 kg (2.2 lbs), makes MOM2 a handheld instrument very suitable for field work, such as in substations.

MOM2 test system is designed to serve a number of applications. The most common are contact resistance measurements of low-, medium- and high-voltage breakers and also at bus-bar joints, and other high current links.

With MOM2 it is possible to make measurements according to the DualGround™ method. This means that the test object will be grounded on both sides throughout the test giving a safer, faster and easier workflow.



MOM200A and MOM600A

MOM200A is designed to check and measure contact resistances in high-voltage circuit breakers, disconnecting switches (isolators) and bus-bar joints. The MOM200A is an excellent choice when 200 amperes or less are needed for measurement. The MOM600A is suitable when there is a need for higher currents.





DLRO200

DLRO200 measures resistances between $0.1 \mu\Omega$ and 1Ω , at high currents. This versatile instrument can provide test currents from 10 A up to 200 A subject to the load resistance and supply voltage. A large liquid crystal display provides all the information needed to perform a test; all test parameters and measurement results are displayed.



DLRO 247000 Series

Digital Low Resistance Ohmmeters (DLRO) are a family of highly accurate instruments that provide a simple, practical and reliable means of making low-resistance tests in the field. They also are ideal for production quality control. They operate on the four-wire measurement principle, thus eliminating lead and contact resistances. With basic accuracies of $\pm 0.25\%$ and resolution down to $0.1 \mu\Omega$, they are nonetheless designed to be rugged and portable for use at the job site.



Primary injection test sets

ODEN A and ODEN AT

Created to test low-voltage and primary breakers, ODEN is designed to generate extraordinarily high power without sacrificing portability. Outputs can range up to many thousand amperes, and thanks to a highly sophisticated measurement section, ODEN has a very broad range of applications.

INGVAR

This powerful test system is designed for primary injection testing of protective relay equipment and circuit breakers. The system consists of a control unit and a current unit. The two parts are portable, and INGVAR can be quickly assembled and connected.

CSU600A and CSU600AT

CSU600A and CSU600AT supply units have two main fields of application. The first is to conduct primary tests on protective relays. A primary test shows whether all parts of the protection system are functioning together properly within the specified time limits under operating conditions.

The second field of application involves conducting current tests on low-voltage circuit breakers and overcurrent devices.

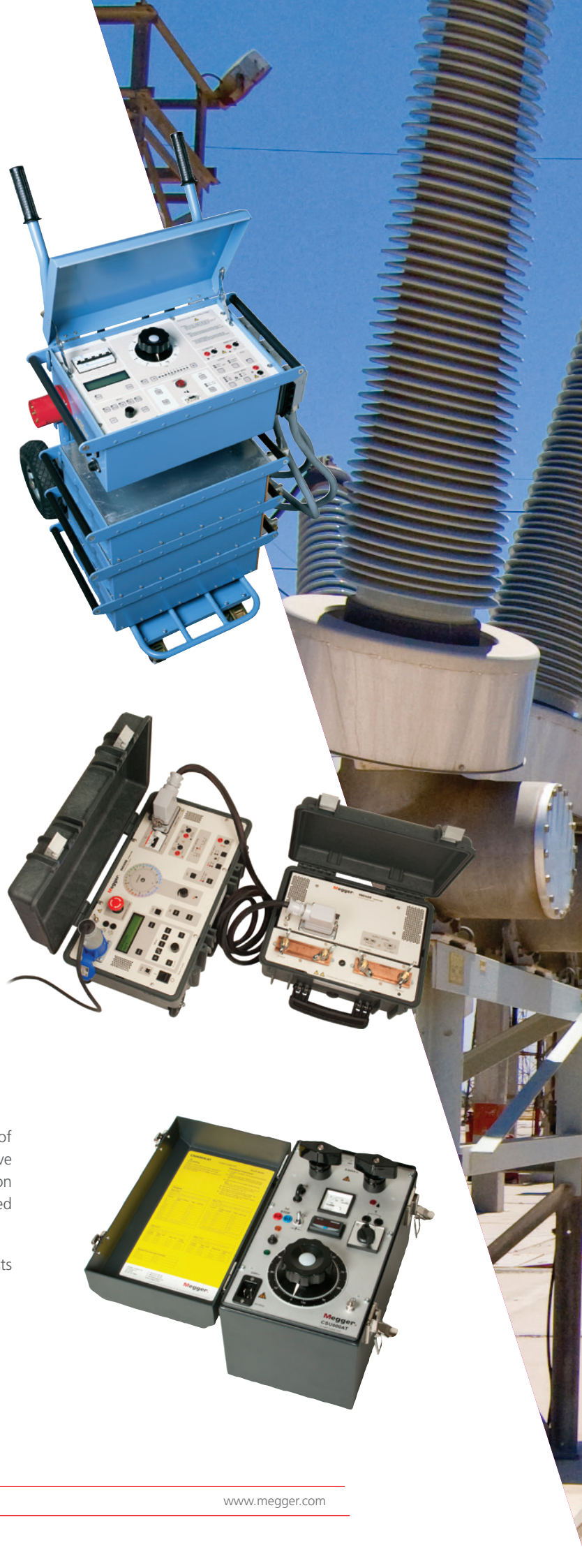



Abbreviations and terms

ABCB	Air-blast circuit breaker
Antipump relay	<p>The relay is there to stop coil from unintentional operating of CB due to remaining close pulse after CO operation.</p> <p>A device that prevents the CB from unintentional operation caused by standing or too long operation command pulses. There are two types:</p> <ol style="list-style-type: none"> Prevents the CB to re-close after a CO when the close command is too long or continuous. The anti-pump relay is reset by releasing the close command pulse. After this the CB can be closed again. Prevents the CB to close when a continuous opening command is applied. To reset the anti-pump relay the opening command has to be removed. When performing a trip-free operation (CO without delay) the open command pulse has to be slightly delayed (10-20 ms) to prevent the anti-pump relay to pick up.
Arc	An electric arc is an electrical breakdown of a gas which produces an ongoing plasma discharge, resulting from a current flowing through circuit breaker medium
Arching contact	Arching contact can be a separate contact or an integral part of the main contact. The purpose of the arching contact is to withstand the energy during switching and protect the main contact from getting burned during arching. Often a material like graphite or tungsten carbide is used in the design.
Auto-reclosing	Auto-reclosing is a short-time interruption of overhead line systems to eliminate transient faults or short-circuits, such as those caused by thunderstorms, lightning or animals. This is simulated at test by performing an Open-delay-Close operation. The delay is normally 300 ms.
Break / Breaking unit / Interrupter	Describes a subcomponent of a circuit breaker that includes at least one main contact. Can also be denoted interrupter. A circuit breaker always includes at least one break per phase and can include up to 6 breaks per phase in extreme cases. The voltage level and application for the specific circuit breaker decides the numbers of breaks.
DCM	Dynamic Capacitance Measurement is a patented method used for resistance measurement with test object grounded on both sides (DualGround). The DCM method is uses high frequency to achieve resonance in the test circuit. The fact that the resonance frequency varies when the circuit breaker changes state can easily be used for close/open detection
DRM	Dynamic Resistance Measurement is a recognized and well-proven method for assessing the condition of circuit breakers. The contact resistance is measured while the circuit breaker operates. From the dynamic behavior of the main- and arcing contact resistance important parameters such as arcing contact wear can be determined.
EHV	Extra High Voltage, ≥ 345 kV
Load switch / Switch disconnecter	Load switch / Switch disconnecter – ANSI/IEEE
Switch	Switch – IEC
Main contact	The main contact is the mechanical part within the interrupter that carries the load when closed and provides the electrical isolation in the open position. The main contact can by design have arching contacts. The typical resistance of the main contact in closed position is 30-50 m Ω .
Micro ohm measurement / SRM / Ducter test	SRM, Static Resistance Measurement, also called micro ohm measurement or ducter test, is a recognized and well-proven method for assessing the condition of circuit breakers. Resistance is measured while the breaker closed. According to ANSI should be measured with at least 100 A.
Nozzle	Part on top of the circuit breaker pole which is protecting the main contacts from the arc between the arcing contacts and also making the gas quench efficiently.
OCB	Oil Circuit Breaker
On line testing	<p>Measurements done when CB is in service and energized. Connections at live parts can not be done. A rough timing measurement can be performed by sensing the presence and absence of current on the secondary side of the current transformers.</p> <p>Moreover, most measurements, in which the operating mechanism is involved can be performed. Examples of such measurements are; coil current, auxiliary contact timing, control voltage, motion and vibration.</p>

Operating mechanism	The operating mechanism includes the energy storage medium, actuating circuit and interlocking systems. Common energy storing mediums are spring, air and hydraulic devices. Depending on the force needed to operate the breaker the circuit breaker is equipped with one operating mechanism per phase (Separate or Independent Pole Operated (IPO)) or one for all three phases (Common or Ganged).
PIR, Post Insertion resistor (opening resistor)	Resistors mounted in parallel with the interrupter as an integral part of the circuit breaker to limit the magnitude of the transient over-voltages. Resistors are mounted on circuit breakers where the over voltages during an opening operation must be controlled or minimized. Post-PIR is in the range of $10\Omega - 10k\Omega$.
S/G, Silver/Graphite	Siemens patented design of HV Circuit breakers where the arcing contact is made out of a graphite material. Traditional arcing contact designs use tungsten carbide. Graphite withstands the energy of the arc generated better but from a measuring perspective it is difficult to detect the open and close time due to high resistance of the graphite.
SF ₆	Gas used in CB and switchgear for its excellent dielectric and arc extinguishing properties as well as for its stability also in high temperatures.
UHV	Ultra High Voltage, ≥ 800 kV



Index

A

Abbreviations and terms	44
Absorbing material	16
ACB	14
Acceleration	27
Air blast	14
Air pressure test	32
Application areas for CB	11
Arc	9
Arcing contacts	9, 16
Auxiliary contacts and coil	17
Auxiliary equipment	39

B

Bulk oil	15
----------------	----

C

Capacitive coupling	34
Capacitor bank breaker	11
Capacitors	10
CB parts	16
CB technologies	14
Cigré	18
Circuit breaker analysers	38
Connections, leads and clamps	35
Contact timing	26
Controlled functionality	10
Controlled switching	28
Control voltage	35
Current	29

D

Damping	27
DCB / DTC	13
DC breaker	12
Dead tank	13
Disconnectors	8
Distribution breakers	12
Disturbances	34
DRM	28
DualGround	22
Dynamic resistance measurement	28

E

Error sources	34
---------------------	----

F

Failure mode analysis	36
Failure modes	18
FAQ	37
First trip test	25

G

General CB function	9
Generator breaker	11
Grading capacitor	10

H

How to test	22
Humidity test	31
HV circuit breakers	11
Hydraulic	17
Hydraulic / Spring	17

I

Inaccuracy	35
Inductive coupling	34
Industrial breaker	12
Interrupter unit	16
Items to be tested	25

L

Live tank	13
Load switches	8
Low voltage CB	13

M

Main and arcing contacts	9
Main contacts	16
Maintenance approaches	20
Maintenance strategy	20
Main types of CB	13
MicroOhmMeters	40
Minimum oil	15
Minimum voltage test	30
Motion	27

Motor	17
Mounting of motion transducer	32
Multiple breaks per phase	10
N	
Nozzle	16
O	
Oil test	31
Operating mechanism	17
P	
Parallel capacitor	10
PIR	10
Pneumatic	17
Power network	8
Primary injection test	26
Primary injection test sets	42
Product selection guide	33
R	
Reactor breaker	11
References	50
Resistor contacts	10
S	
Safety	22
Sampling frequency	35
SDRM202	39
SF6	15
SF6 leakage	31
Solutions to reduce the arc	9
Speed	27
Spring loaded	17
SRM	27
Standards	7
Static resistance measurement	27
Switch disconnecter	12
Synchronized functionality	10
Synchronized switching	28

T

Temperature	34
Test equipment	33
Testing guide	21
Test methods	25
Test results	36
Thermal / Magnetic	17
Timing of graphite breakers	26
Traction CB	12
Transducer and flex coupling tolerances	35
Travel	27

V

Vacuum	15
Vacuum bottle test	31
Vibration testing	30
Voltage	29
Voltage supply	35

W

Why test circuit breakers	6
---------------------------------	---



References

1. "Colloquium on Monitors and condition assessment equipment". IEE 1996.
2. H.V. Stephandes et al, "Modern Methods for the Reduction of the Operating Energy for SF Circuit Breakers". CIGRE 13-12 1993.
3. H. Aeschbach et al, "Maintenance of SF High Voltage Circuit Breakers". CIGRE 23- 105 199
4. Interpretation of Circuit Breaker Operating Coil Signatures
5. W. E. Dueck Programma Electric AB
6. Ferrography and Electrical Switching Apparatus Mike Munroe Leslie Morovek Bill Dueck MUNROE EQUIPMENT SERVICES MUNROE EQUIPMENT SERVICES MANITOBA HYDRO
7. Anderson, D. P. / Wear Particle Atlas (Revised) / 1982 / page 7
8. Anderson, D. P. / Wear Particle Atlas (Revised) / 1982 / page 8
9. Scott, D. and Mills, G. H. / Spherical Debris- It's Occurrence, Formation, and Significance in Rolling Contact Fatigue / Wear, 24 / 1973 / pages 235-242
10. Anderson, D. P. / Wear Particle Atlas (Revised) /1982 / page 34
11. Lockwood, F. E. , Dalley, R. /Lubricant Analysis/Friction, Lubrication, and Wear Technology/1995 /page 30
12. Hogmark, S. , Jacobson, S., Vingsbo, O. , / Technology / 1995 / page 176
13. Oerilikon Engineering Company / Service Publication H 401620 / 1969 / Pages 5 and 6
14. Imperial Oil / Product Information / Ninth Edition / 1996 / page 138
15. Stadnyk, N. M. , Tandon, K. N. / Industrial Technology Center / Project #01340 / 1984 / page 1
16. Stadnyk, N. M. , Tandon, K. N. / Industrial Technology Center / Project #01340 / 1984 / page 3
17. Michael Beanland, P.E., TriAxis Engineering, Corvallis, OR Thomas Speas, Southern States LLC, Hampton, GA
18. Joe Rostron, P.E., Southern States LLC, Hampton, GA Prepared for Western Protective Relay Conference October 19-21, 2004 Spokane, WA
19. Mirsad Kapetanovich, "High voltage circuit breakers"
20. Live Tank Circuit Breaker, Buyer's Guide, Edition 3, 2004-06, ABB
21. Roberto Pilenga, Jornadas Técnicas Medium Voltage Service Retrofit & Revamping, ABB
22. CE Sölver, ABB Ludvika

What's in the name...?

For over 100 years, Megger has been a premier provider of test equipment and measuring instruments for electrical power applications. The Megger trademark was first registered in May 1903 and is closely guarded by the company. Although Megger is best known for its world-famous range of insulation testers, the company provides a full service solution to meet all electrical test and measurement needs. Megger products provide testing solutions for the most critical maintenance areas, including cable fault location, protective relay and circuit breaker testing, and power quality testing. With such a diverse product offering, Megger is the single source for electrical test and measuring instruments.

The Megger product offering spans 30 distinct product groups with over 1,000 specific products. Circuit breaker test sets, watt-hour meter test equipment and protective relay test instruments, instruments used for testing and maintaining transformers, batteries and underground cables and other products designed for the power industry were formerly supplied under the Biddle, Multi-Amp, PAX Diagnostics and Programma brands. As a few examples of its many innovations, Megger developed the first completely automatic, software driven protective relay test system in 1984 as well as the first microprocessor based breaker test system in 1984.

Manufacturing insulation testers from 1 kV to 10 kV is where Megger started, and the Megger brand name is so well known today that maintenance professionals often incorrectly use it as a verb when they refer to insulation testing on wiring. This famous name dates back to 1889, when the first portable insulation tester was introduced with the MEGGER brand.

Megger acquired PAX diagnostics in 2008, adding sweep frequency diagnostic test equipment to its portfolio. Megger enjoys an outstanding reputation in the areas of ground testing, oil testing and as a supplier of electrical contractor maintenance tools such as multimeters, portable appliance testers and clamp-on meters.

In June 2012, Megger acquired SebaKMT, the world leader in cable test equipment. While Megger invented DC insulation resistance testing in the 19th century, it was Seba that pioneered cable fault location equipment in the early 1950s.

One recent addition to the Megger product line is an innovative range of instruments for testing data and telecommunication installations. Working with both copper and optical technologies, and collaborating closely with the major industry players, Megger has developed easy-to-use products to keep the costs of test and measurement down and productivity up.

Megger also operates the renowned AVO Training Institute, which offers top rated training for electrical maintenance and

safety through the network of Megger offices. In addition, the company manufactures STATES superscript terminal blocks and test switches, which are specified by many major electric utilities. For over 65 years, test technicians and engineers have depended on STATES products to provide easy access to wiring on panel boards and switchboards, to eliminate wiring reconnection errors and to save operator time.

Megger manufactures and markets products on a global scale. Its principal manufacturing sites are in College Station and Dallas, Texas; Valley Forge, Pennsylvania, Dover, England, Danderyd, Sweden and Baunach and Radeburg, Germany. Sales and technical support offices are maintained at each manufacturing site as well as in Sydney, Australia; Toronto, Canada; Paris, France; Oberursel, Germany; Mumbai, India, Johannesburg, South Africa; Oberkulm, Switzerland, Chonburi, Thailand and Bahrain, UAE. With a global network of hundreds of sales representatives, product literature and user manuals in eight languages, and multilingual product software, Megger is a local supplier for customers anywhere in the world.

All Megger products meet the highest standards for quality, reliability and safety. All of the company's facilities are certified as meeting the requirements of the ISO 9001 quality standard, and the Dover and Danderyd sites are also certified to ISO14001, the international environmental standard. Megger is constantly striving to maximize quality, thereby ensuring that the experience of its customers is always world class





Megger Limited
Archcliffe Road
Dover CT17 9EN
United Kingdom

www.megger.com

Circuit_Breaker_Testing_Guide_AG_en_V02

The word 'Megger' is a registered trademark. Copyright © 2022

Megger[®]