

Instruction Manual AVTM835140

for

**Battery Ground Fault Locator
No. 835140 and 835140-1**

High Voltage Equipment

Read the entire manual before operating.

Aparato de Alto Voltaje

Antes de operar este producto lea este manual enteramente.

Megger[®]

400 Opportunity Way
Phoenixville, PA 19460 U.S.A.
Tel.: 610-676-8500

www.megger.com

Instruction Manual AVTM835140

for

**Battery Ground Fault Locator
No. 835140 and 835140-1**

Copyright 2003 by Megger. All rights reserved.

The information presented in this manual is believed to be adequate for the intended use of the product. If the product or its individual instruments are used for purposes other than those specified herein, confirmation of their validity and suitability must be obtained from Megger. Specifications are subject to change without notice.

Megger®

400 Opportunity Way
Phoenixville, PA 19460 U.S.A.
Tel.: 610-676-8500

www.megger.com

TABLE OF CONTENTS

1	OPERATOR SAFETY	1
1.1	Description.....	1
1.2	Explanation Of Safety Symbols	1
1.3	Grounding.....	2
1.4	Power Cord And Fuses.....	2
2	GENERAL INFORMATION	3
2.1	Description.....	3
2.2	Features	3
2.3	Specifications.....	4
2.3.1	Test Signal Output.....	4
2.3.2	Withstand Capability.....	4
2.3.3	Loading	4
2.3.4	Warning Signal.....	4
2.3.5	Input Current Sensors.....	5
2.3.6	Accuracy And Sensitivity	5
2.3.7	Sensitivity.....	6
2.3.8	Ripple Tolerance.....	6
2.3.9	Meter Response Time	6
2.3.10	Current Sensor Output.....	6
2.3.11	Instrument Power Supply	7
2.3.12	Accessories	7
2.3.13	Physical	7
2.3.14	Operation	8
2.4	Changes	8
2.5	Warranty	8
3	INSTALLATION	11
3.1	Unpacking And Inspection.....	11
3.2	Preparation For Use.....	11
3.3	Line Supply Voltage.....	11

- 3.4 Repacking And Shipment..... 12
- 4 OPERATING INSTRUCTIONS..... 13
 - 4.1 Panel Controls And Operating Functions 13
 - 4.2 Principle Of Operation 16
 - 4.3 Safety Considerations 16
 - 4.3.1 Output Lead Set 16
 - 4.3.2 Input Sensor 18
 - 4.3.3 Recommended Operator Precautions..... 18
 - 4.4 General Operating Procedure - Resistance & Capacitance 18
 - 4.4.1.General Procedure..... 18
 - 4.4.2 Led Measurement Status Indicators 20
 - 4.4.3 Measurement Of Capacitance 21
 - 4.5 Determining The Total Resistance Or Capacitance To Ground..... 23
 - 4.6 Procedure For Locating Ground Faults 25
 - 4.6.1 General 25
 - 4.6.2 Steps To Locate A Ground Fault..... 25
 - 4.7 Multiple Faults..... 29
 - 4.7.1 General 29
 - 4.8 Battery Systems With Capacitive Loading (Transient Suppression)..... 31
 - 4.8.1 Descripton..... 31
 - 4.8.2 Accuracy Vs Capacitive Loading 33
 - 4.9 Battery Systems With Switching Loads..... 33
 - 4.10 Power Frequency And Harmonic Ripple 34
 - 4.11 Sensor Output..... 35
- 5 SERVICE AND MAINTENANCE 36
- 6 DOCUMENTATION..... 38

LIST OF FIGURES

Figure 4-1 – Panel Controls And Operating Functions15

Figure 4-2 – Connection To A Battery System17

Figure 4-3 - Connection To Main Breaker Panel.....22

Figure 4-4 - Detecting The Total Resistance And Capacitance To Ground24

Figure 4-5 - Locating Ground Faults28

Figure 4-6 - Locating Multiple Ground Faults.....30

Figure 4-7 - Battery System With Capacitive Loading.....33

Figure 4-8 - Waveforms With Switching Annunciator Lamp Load.....34

Megger[®]

1

OPERATOR SAFETY

ATTENTION

READ THIS MANUAL BEFORE PROCEEDING WITH INSTALLATION AND OPERATING THE INSTRUMENT.

Sur demande, les directives sur la sécurité de l'opérateur sont disponibles en français.

1.1 DESCRIPTION

This instrument must be operated, used and serviced **ONLY** by trained, qualified personnel. Misuse of electrical instruments can result in personal injury and damage to the apparatus under test. Obey all applicable safety rules and regulations at all times.

Refer to the following sections of this manual for operating specifications and procedures.

1.2 EXPLANATION OF SAFETY SYMBOLS

Megger uses, where applicable, the following IEC 417 symbols on its instruments:



This symbol indicates that the operator of the instrument must refer to the instruction manual for further explanation and clarification.



Safety Ground Terminal. This terminal must be connected to an earth ground before making other connections to the instrument and prior to operating it.



This *red* symbol indicates that high voltage (i.e. any voltage equal or greater than 1000 Volts) is present on the terminal. Use extreme care.



This is the symbol for a sinusoidal AC voltage or current.

1.3 GROUNDING

Where a ground binding post or a grounding lead is provided on the instrument, it must be connected to an earth ground **PRIOR** to making any other connections.

WARNING

To avoid electric shock do not interrupt the connection to the protective safety ground.

1.4 POWER CORD AND FUSES

The power cord must be connected to a grounded supply system with proper electrical ratings, as indicated on the instrument.

In the case of detachable power cords, only the cord supplied or specified by Megger should be used.

WARNING



TO AVOID ELECTRIC SHOCK ALWAYS DISCONNECT THE POWER CORD FROM THE SUPPLY CIRCUIT BEFORE SERVICING THE INSTRUMENT OR WHEN REPLACING A FUSE.

WARNING



ALL FUSES MUST BE REPLACED WITH THE SAME TYPE AND CURRENT AND VOLTAGE RATINGS. SHORT-CIRCUITING THE FUSEHOLDER IS PROHIBITED.

2

GENERAL INFORMATION

2.1 DESCRIPTION

The Megger Battery Ground Fault Locator is a portable instrument used for detecting, tracing and locating ground faults on battery systems. The instrument's operation is based on injecting a low frequency AC signal between the battery system and ground and then synchronously detecting the resulting current. The instrument is capable of tracing single or multiple ground faults on battery systems that are fully isolated, or resistance grounded. The tracing and locating procedure for finding a ground fault does not require a shutdown or sectionalization of the battery system.

2.2 FEATURES

- Lightweight and portable
- Reads directly in resistance or capacitance
- Wide operating range (1 ohm to 100 Kohms)
- Automatic operation; Easy to use
- Locates multiple faults
- Battery operated with built-in charger
- Protected against battery system transients
- Built-in memory for last reading comparison
- Operates with capacitive loading and reads capacitance

2.3 SPECIFICATIONS

2.3.1 TEST SIGNAL OUTPUT

	60Hz Operation	50Hz Operation
Shape:	sinusoidal	sinusoidal
Frequency:	25Hz \pm 1Hz	21Hz \pm 1Hz
Maximum Output Voltage:	3.5VAC (open circuit)	3.5VAC (open circuit)
Maximum Output Current:	120mA (short circuit)	100mA (short circuit)
Output Impedance for 25Hz:	66 ohms, nominal	78 ohms, nominal
Equivalent D.C. Resistance:	10 Mohms	10 Mohms

2.3.2 WITHSTAND CAPABILITY

Output of the instrument will withstand continuous connection across a battery system of 250VDC nominal.

2.3.3 LOADING

The Battery Ground Fault Locator will draw a maximum of 250 μ A D.C. when connected to a 250VDC battery system. A battery system may be subject to pulse loading, while connecting the instrument to a battery system. This loading is caused by charging an internal decoupling capacitor through the ground fault resistance. For the worst case condition at 250VDC battery system and 0 ohms fault resistance, the pulse loading is 50A for 1.5mS.

2.3.4 WARNING SIGNAL

A *red* LED illuminates when the D.C. voltage across output terminals exceeds 30VDC.

2.3.5 INPUT CURRENT SENSORS



For safety reasons only one of the following sensors should be used with this instrument.

STANDARD CLAMP-ON CURRENT SENSOR (835142)

Maximum Physical Opening:	2.5 inches.
Dielectric Strength:	1 kV AC.
Maximum DC Bias:	25A.
Maximum AC Ripple Current:	0.5A.

MINI CLAMP-ON CURRENT SENSOR (OPTIONAL, 835146)

Maximum Physical Opening:	1 inch.
Dielectric Strength:	1 kV AC.
Maximum DC Bias:	5A.
Maximum AC Ripple Current:	0.5A.

BUS BAR CLAMP-ON CURRENT SENSOR (OPTIONAL, 835147)

Maximum Physical Opening:	2 x 4 inches.
Dielectric Strength:	1 kV.
Maximum DC Bias:	50A.

2.3.6 ACCURACY AND SENSITIVITY

ACCURACY USING CLAMP-ON C.T. (835142):

Range:	1 ohm - 100 Kohms
Basic Accuracy:	$\pm 20\%$ of reading with a system capacitance less than $100\mu\text{F}$ - $1\mu\text{F}$, respectively.

USING MINI CLAMP-ON (835146):

Range:	1 ohm - 10 Kohms
--------	------------------

Basic Accuracy: $\pm 30\%$ of reading with a system capacitance less than $100\mu\text{F}$ - $1\mu\text{F}$, respectively.

USING BUS BAR CLAMP-ON (835147)

Range: 1 ohm - 10 Kohms

Basic Accuracy: $\pm 30\%$ of reading with a system capacitance less than $100\mu\text{F}$ - $1\mu\text{F}$, respectively

2.3.7 SENSITIVITY

The Battery Ground Fault Locator is capable of locating single or multiple faults, without subsequent troubleshooting, if output load impedance is higher than 66 ohms in 60Hz version (78 ohms for 835140-1). Below this value accuracy deteriorates. The capacitance to ground of the system affects sensitivity and accuracy.

2.3.8 RIPPLE TOLERANCE

The instrument is designed to reject up to 0.5 ampere of ripple current composed of the power frequency and its harmonics (up to about 500Hz). Saturation and therefore incorrect operation results above this value.

2.3.9 METER RESPONSE TIME

Three seconds nominal after "Valid" LED illuminates.

2.3.10 CURRENT SENSOR OUTPUT

Trans-Impedance: 1A = 10 volts (10 ohms)

Maximum Output: 14V pk-pk

Output Resistance: 2.0 K Ω

2.3.11 INSTRUMENT POWER SUPPLY

Internal, sealed, lead-acid rechargeable battery giving a minimum of 8 hours of continuous operation on full charge. Internally protected against charge exhaustion and overcharging by a temperature compensated charging circuit, 10 - 12 hour recharge time.

Instrument may be operated while recharging through standard CEE three-pin line socket with built-in fuse and spare.

Yellow LED illuminates when A.C. line power is applied to line socket.

Yellow LED illuminates when battery is 90% recharged.

2.3.12 ACCESSORIES

ACCESSORIES FURNISHED

MC1495	Line cord (SVT Type, 18 AWG, 3 conductor)
835141	Instruction Manual
835142	Clamp-on Current Sensor
835143	Output Lead, 2 meter
835144	Output Extension Lead, 4.5 meter
835145	Fault Simulator

ACCESSORIES AVAILABLE

835146	Mini Clamp-On Current Sensor, 1 inch opening
835147	Bus Bar Clamp-on Current Sensor

2.3.13 PHYSICAL

Instrument is supplied in a portable fiberglass case with lead storage compartment and removable cover.

Sizes: 330W x 280H x 180D millimeters
(13W x 11H x 7D inches)

Weight:
Instrument: 11.3 kg (25 LBS)
Shipping: 13 kg (29 LBS)

2.3.14 OPERATION

ENVIRONMENTAL:

Operating: 0°C to 50°C, R.H. to 80%
Storage: -40°C to +65°C

2.4 CHANGES

Please note that this instrument is subject to continuous development and improvement. This instrument may therefore incorporate minor changes in detail from the information contained herein.

2.5 WARRANTY

Megger warrants this equipment, sold by us or our authorized agents, to be free from defects in material and workmanship, reasonable wear and tear excluded, for a period of 12 months from date of shipment.

Warranty service will be performed on the equipment at the Megger factory (unless the return of only a subassembly is authorized by Megger) or, at Megger's discretion, in the field. The customer shall prepay shipping charges for units returned to Megger, and Megger shall pay for the return of the required or replaced unit to the customer, repair or replace (at Megger's option) the unit or subassembly provided that the Instrument has not been altered, modified or repaired by unauthorized personnel, and that our examination discloses to our satisfaction that any improper operation or failure was not the result of improper use, negligence or accident, exceeding environmental limits, or connecting the Instrument to incompatible equipment. The customer is asked to obtain return authorization from Megger PRIOR TO returning a unit for service.

This warranty covers the cost of repairing or replacing faulty components at Megger's option, but not the cost of travel and living expenses of service personnel for work completed in the field. Any field service trips will be subject to inspection of the Megger service representative. If it is determined upon arrival that the repair is not covered by the Warranty, the customer must be prepared to cover the standard rates of the Megger service representative(s) in addition to the cost of travel and living expenses of the service personnel.

The invoice for the full amount of the non-warranty repair will be submitted by the Megger office upon the return of the service representative. The customer must remit the required payment immediately for all service work performed.

NO OTHER WARRANTY IS EITHER EXPRESSED OR IMPLIED. MEGGER SHALL NOT BE LIABLE FOR CONSEQUENTIAL DAMAGES.

Products manufactured by Megger to customer's specifications are warranted to be free from defects in material and workmanship and to conform to those specifications made a part of Megger's quotation, or of a customer's Contract or Purchase Order. Inspection and acceptance shall be conclusive as to fulfilling this warranty, except as to fraud or such gross mistakes as to amount to fraud.

SINCE MEGGER HAS NO CONTROL OVER CONDITIONS OF USE, NO WARRANTY IS MADE OR IMPLIED AS TO SUITABILITY FOR CUSTOMER'S INTENDED USE BEYOND SUCH PERFORMANCE SPECIFICATIONS AS ARE MADE A PART OF MEGGER'S QUOTATION, OR OF A CUSTOMER'S CONTRACT OR PURCHASE ORDER WHICH HAS BEEN APPROVED AND ACKNOWLEDGED BY MEGGER.

Megger[®]

3

INSTALLATION

3.1 UNPACKING AND INSPECTION

Prior to shipment this instrument was electrically tested and mechanically inspected and found to meet specifications and be free of mechanical defects.

After unpacking the instrument, visually inspect the instrument and accessories for damage. If evidence of damage is present, YOU must contact the carrier who transported the unit and file a claim in writing. The shipping container and packing material should be retained for inspection by the carrier's agent. Electrical operation per section 4 should be checked as soon as possible after shipment.

3.2 PREPARATION FOR USE

THIS INSTRUMENT IS DESIGNED TO BE USED IN SYSTEMS WITH POTENTIALLY LETHAL VOLTAGES AND CURRENTS. It is highly recommended that the user familiarize himself with the controls, functions and features detailed in section 3 prior to use. ALL SAFETY PROCEDURES AND PRECAUTIONS MUST BE FOLLOWED WHEN OPERATING ON LINE WITH LETHAL VOLTAGES OF HIGH CAPACITY.

3.3 LINE SUPPLY VOLTAGE

The instrument line voltage is clearly indicated on the front panel and **must** be checked before plugging the instrument in. The voltage should correspond to the voltage used in your country.

3.4 REPACKING AND SHIPMENT

To insure proper shipment of this instrument it is recommended that the original reusable container and packing material be retained. If being returned for calibration or service, please attach a card to the instrument specifying the owner, model and serial number and service required.

4

OPERATING INSTRUCTIONS

4.1 *PANEL CONTROLS AND OPERATING FUNCTIONS*

Refer to Figure 4-1.

1. Line Input Socket - Standard input for line cord. Fuse plus spare is located above socket.
2. AC Line - Illuminates when the input plug is connected to a live circuit.
3. Battery Charged - Illuminates when the battery is 90% recharged.
4. Power ON/Battery Check - Toggling this switch to the middle position activates the instrument (one of four measurement LEDs will illuminate). Flipping switch to upper position activates the battery check feature. Instrument meter should deflect to scale marking.
5. Function - This switch enables selection of the resistance or capacitance on meter display (13).
6. Memory - This switch normally rests in the middle position when present resistance reading is displayed. Toggling this switch to the upper position stores valid resistance or capacitance measurement in memory. Toggling this switch to the lower position recalls previously stored resistance value, to be displayed on the meter.
7. Warning > 30VDC - This LED illuminates when there is higher than 30VDC present across the instrument's output terminals. THIS WARNING LIGHT INFORMS OPERATOR OF A POTENTIALLY LETHAL VOLTAGE ACROSS INSTRUMENT OUTPUT TERMINALS. (May persist after disconnection).
8. Output - Jack for output lead set connection.

9. Input Overload - Illuminates when measured current signal exceeds input circuitry handling capability. This may occur when battery charging current ripple exceeds 0.5A, or AC current drawn by a load is present.
10. Overrange - Illuminates when measured resistance is higher than approximately 200K ohms.
11. In Progress - Illuminates when the meter reading is stabilizing. Indication may not be valid when this LED is illuminated.
12. Valid - Illuminates when the meter indication is within specified accuracy.
13. Ohmmeter/Capacitance/Battery Check Indication - This meter reads resistance, capacitance, or verifies battery condition, as required.
14. Input Sensor - Input connector for the clamp-on Current Sensor.
15. Sensor Output - This is a replica of the current being sensed by the Current Sensor, after it has passed through a 25Hz (21Hz for 835140-1) notch filter. It allows the operator to monitor battery system current ripple using an oscilloscope or recorder. It does not measure any of the D.C. component of the current, neither does the output contain any of the low frequency measured current.

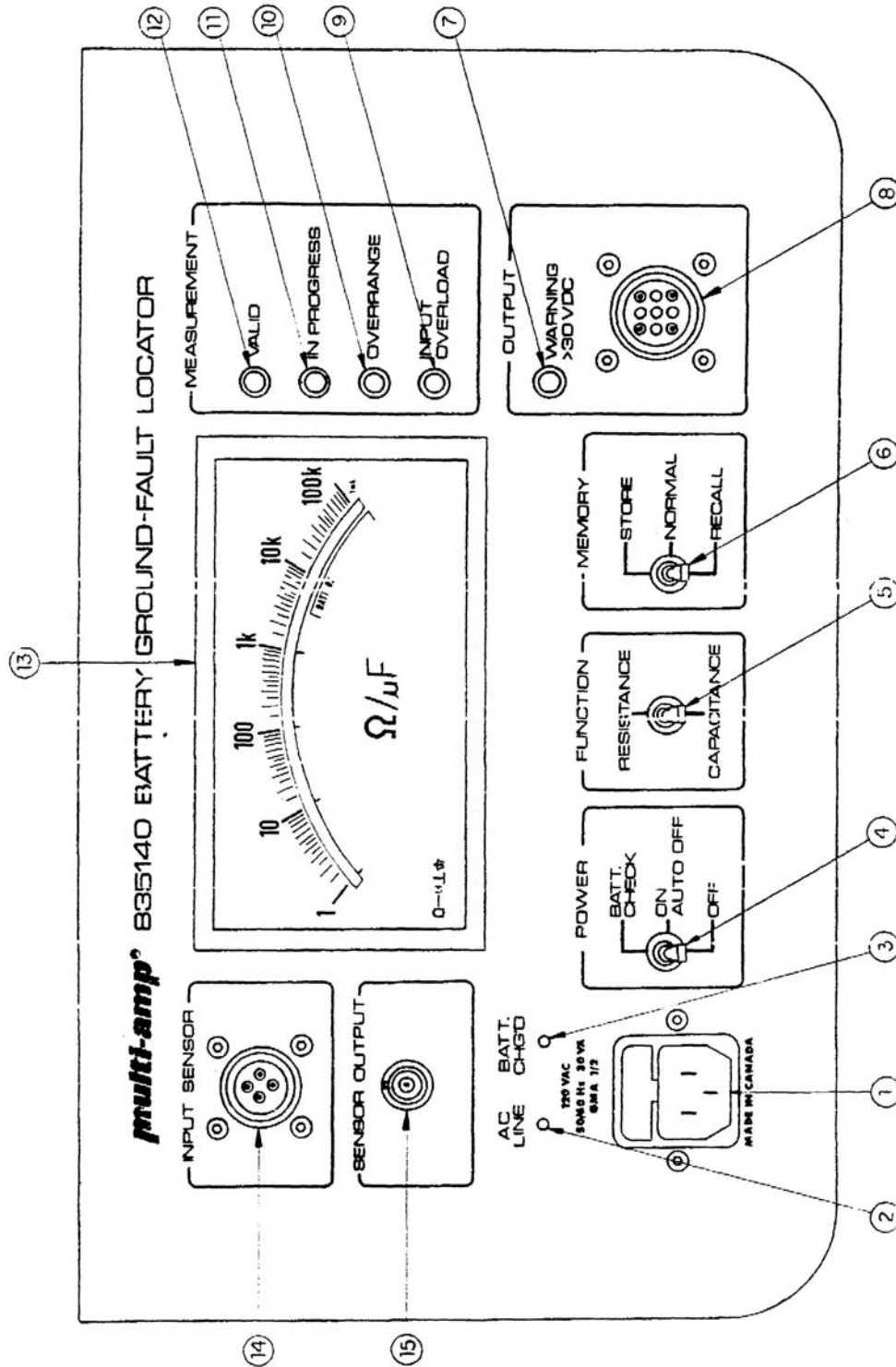

Figure 4-1: Panel Controls and Operating Functions

4.2 PRINCIPLE OF OPERATION

The Megger Battery Ground Fault Locator measures ground fault resistance in battery systems by:

1. Injecting an AC voltage between station ground and battery system.
2. Measuring the resulting circulating current with a clamp-on C.T. used as the current sensor.
3. Calculating resistance value by comparing the injected voltage to the in-phase component of the circulating current.

When the signal is injected at the battery terminal, and the clamp-on C.T. is connected to the outgoing lead, the instrument will measure the total ground faults and leakage resistance present on the battery system. If the C.T. is clamped on only one feeder, then the instrument will measure only the ground fault on that feeder.

The instrument has a built-in timer which helps to conserve battery life. It will turn off the instrument after approximately 5 minutes of measurement inactivity and will do so even if the instrument is powered off the line. Every time the valid LED is turned on the timer is reset. This means that whenever the C.T. is re-clamped to the system, operation is extended for a further 5 minutes. When the instrument is turned off by the internal timer it can be turned on again by toggling the power switch.

The clamp-on C.T. used as the current sensor for this instrument is made with an iron core. To avoid saturation of the core with DC current, the current must be less than 25 amperes. Core saturation may cause a false reading.

The BGL measures capacitance in much the same manner as is described above. The difference is in item 3 above, where the quadrature component of the current is used to calculate the capacitance.

4.3 SAFETY CONSIDERATIONS

4.3.1 OUTPUT LEAD SET

A three lead output set, complete with connector is provided for connecting to the battery system to be tested. Connect it to "Output" connector (8).

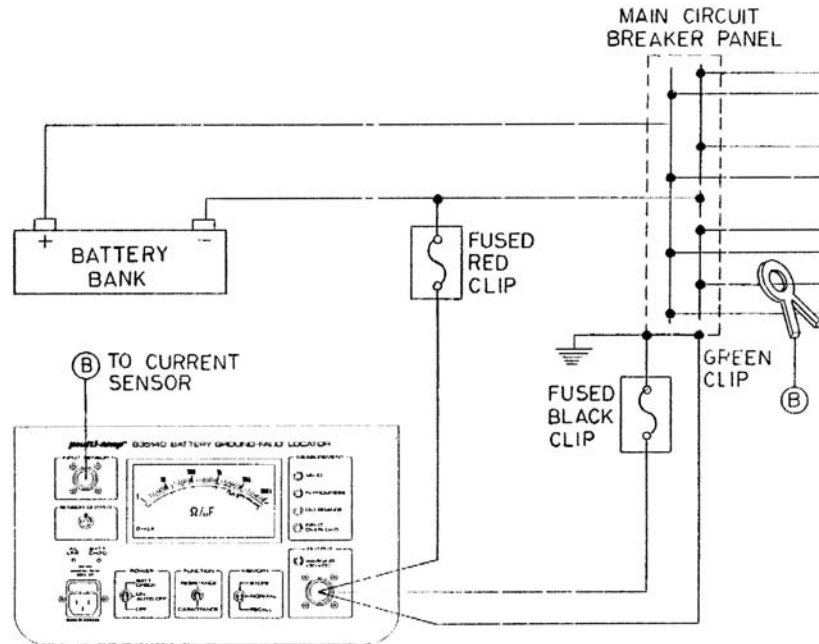

Figure 4-2: Connection to a Battery System

Connect to battery system as follows:



- STEP 1. Green clip to system ground. This is the safety case ground.
- STEP 2. Fused *black* clip to system ground.
NOTE: This is output signal return.
- STEP 3. Fused *red* clip to negative or positive bus.

Disconnection from a battery system:

- STEP 1. Remove fuse *red* clip from battery bus. **DO NOT TOUCH** bare end as voltage is still present via an internal coupling capacitor, charged to battery voltage.
- STEP 2. Place *red* clip to ground so as to discharge internal coupling capacitor.

NOTE: Warning > 30VDC *red* LED should turn off when discharge is complete.

STEP 3. Remove fused *black* clip.

STEP 4. Remove *green* clip.

4.3.2 INPUT SENSOR

Clamp-on current sensor is first connected to instrument. Iron core of sensor is electrically isolated from its output. Contact of iron core with live D.C. bus will not cause an electrical hazard.

4.3.3 RECOMMENDED OPERATOR PRECAUTIONS

Most Utilities have safety rules and procedures that must be observed when working on battery systems that may supply large amounts of current to a fault. All of these should be observed, suggested precautions should include:

1. The use of electrical safety gloves when in close proximity to bare battery bus work.
2. The use of safety glasses with optional tint (for H.V. arcing).

4.4 GENERAL OPERATING PROCEDURE - RESISTANCE & CAPACITANCE

Refer to Figures 4-2 and 4-3 for clarification of procedure.

4.4.1 GENERAL PROCEDURE

1. Turn instrument on. After initial "In progress" LED illumination, the "Overrange" LED should illuminate. If it does not illuminate, instrument battery is probably exhausted. Instrument should either be allowed to recharge or powered from an AC line.

If power switch is in 'on' position when commencing, the unit may have the 'auto-off' enabled. To reset, simply place the switch to 'off ' and then back to the 'on' position.

2. Connect "Current Sensor" and "Output Lead Set" to the instrument.
3. Connect Output Lead Set to battery system in the following sequence:
 - STEP 1. Connect *green* clip to station ground.
 - STEP 2. Connect *black* clip to battery system ground.
 - STEP 3. Connect *red* clip to positive or negative battery bus bar.

"Warning > 30VDC" LED may turn on.
4. Clamp "Current Sensor" around *red* instrument output lead.
5. Place "Function" switch (5) to resistance position.
6. Wait for "Valid" LED to illuminate. Observe meter indication. Resistance displayed is equal the TOTAL parallel resistance to ground of the battery system from ALL leakage paths, including both positive and negative poles and any battery grounding resistor that may be used.

NOTE: If this resistance is high (in excess of 10 Kohms) the chances of finding any problems is limited.
7. Remove clamp-on in step 4 and connect around one branch circuit lead.
8. Wait for "Valid" LED to illuminate. Observe meter indication. Meter indication is the resistance to ground of this branch forward.

NOTE: Any resistance-to-ground between the red (output) lead and the location of the clamp-on C.T. will NOT be measured, as its current does not pass through the clamp-on sensor.
9. Repeat Step 7 until finding the faulted branch. If a low resistance-to-ground is found, use the instrument "Memory" feature. Toggle switch upward to store this value of leakage resistance. This will be useful later when further isolating problem. This resistance can be compared with other leakage resistances to determine whether ALL or part of leakage exists at any particular point.
10. When terminating measurements, first unclasp the "Current Sensor", then disconnect "Output Lead Set" in the following sequence.

- STEP 1. Disconnect *red* clip from battery bus bar and if "Warning > 30VDC" *red* LED illuminates, momentarily connect it to system ground to turn off this LED
- STEP 2. Disconnect *black* clip from battery ground.
- STEP 3. Disconnect *green* clip from station ground.

4.4.2 LED MEASUREMENT STATUS INDICATORS

1. "INPUT OVERLOAD" - This LED will illuminate if the magnitude of the sensed AC current signal exceeds 0.5A.

- Resolution:
1. Proceed to different branch or to point past battery chargers.
 2. Turn off battery charger temporarily.
 3. Since the return load current is typically also available, the overload condition can be eliminated by clamping around both conductors.

This LED will also illuminate if the magnitude of DC current exceeds 20A. The same cancellation effect applies to the AC ripple problem.

2. "OVERRANGE" - This LED will illuminate if resistance to ground exceeds 200K ohms. Branch is free from ground fault if this LED illuminates.

Resolution: Proceed to different branch

Since the return load current is typically also available, the overload condition can be eliminated by clamping around both conductors.

3. "IN PROGRESS" - This LED stays on for the period of time it takes the instrument to determine a reading (typically 3 - 7 seconds). If this LED continually stays on, or is erratic, problem may be a changing fault resistance or changing levels of DC current on the branch (caused by breaker, relay, or lamp activity).
4. "VALID" - This LED indicates a correct reading. Depending on circuit conditions, it may be necessary to wait a second or two for the meter to stabilize, before taking the meter reading.

4.4.3 MEASUREMENT OF CAPACITANCE

Capacitance measurements are done in exactly the same manner as outlined in steps 1-10 with the exception of step 5; where the switch is set to 'capacitance'.

Step 6 will give the operator total capacitance to ground for the battery system. This should be measured prior to doing resistance measurements to ensure all readings will be totally valid. A very high capacitance ($> 100\mu\text{F}$) will affect accuracy of resistance readings. (See section 4.8)

NOTE: It should be pointed out that the polarity of the clamp-on C.T. does NOT affect resistance or capacitance readings.

By following the wiring, and making consecutive measurements, one can determine the location of the ground fault being traced. Although simultaneous (multiple) ground faults can be easily traced, high resistance grounds are difficult to trace in the presence of low resistance grounds. One should always trace, locate, and correct the low resistance faults first.

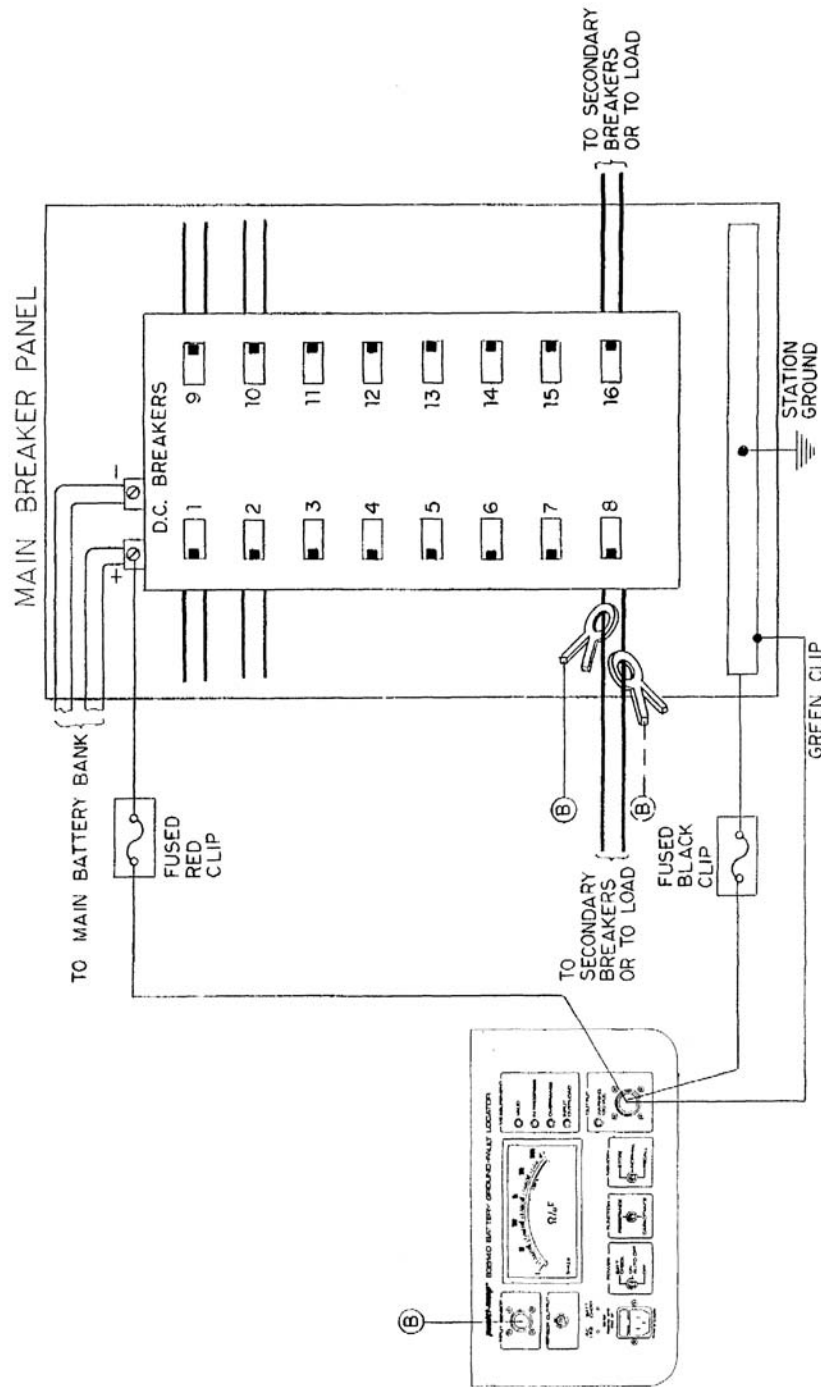

Figure 4-3: Connection to Main Breaker Panel

4.5 DETERMINING THE TOTAL RESISTANCE OR CAPACITANCE TO GROUND

Refer to Figure 4-4 for further clarification of procedure.

Most battery systems are equipped with detectors that will indicate the presence of a ground fault. If this indication is not available or if an operator wants to verify its proper operation, the following procedure should be used.

Refer to section 4.3. Safety Considerations, before proceeding.

1. Connect *green* fused clip to station ground.
2. Connect *black* fused clip to station ground.
3. Connect *red* fused clip directly to battery post (positive or negative).
4. Clamp C.T. on the *red* fused lead wire.
5. Wait for "Valid" LED to come on and meter to settle.
6. Meter will indicate total ground resistance between battery system and ground, including grounding resistance.
7. Clamp C.T. on positive bus leaving battery. Meter will indicate only the ground resistance on the positive pole of the battery.
8. Clamp C.T. on negative bus leaving battery. Meter will indicate only the ground resistance on the negative pole of the battery.
9. By switching to the "capacitance" function in steps 6, 7 and 8 the associated capacitances can be measured.

NOTE: A small spark may occur when connecting to battery terminals. The initial placement of fused red clip on battery terminal (step 3) may cause ground detectors to momentarily alarm due to large inrush of current to the Battery Ground Fault Locator.

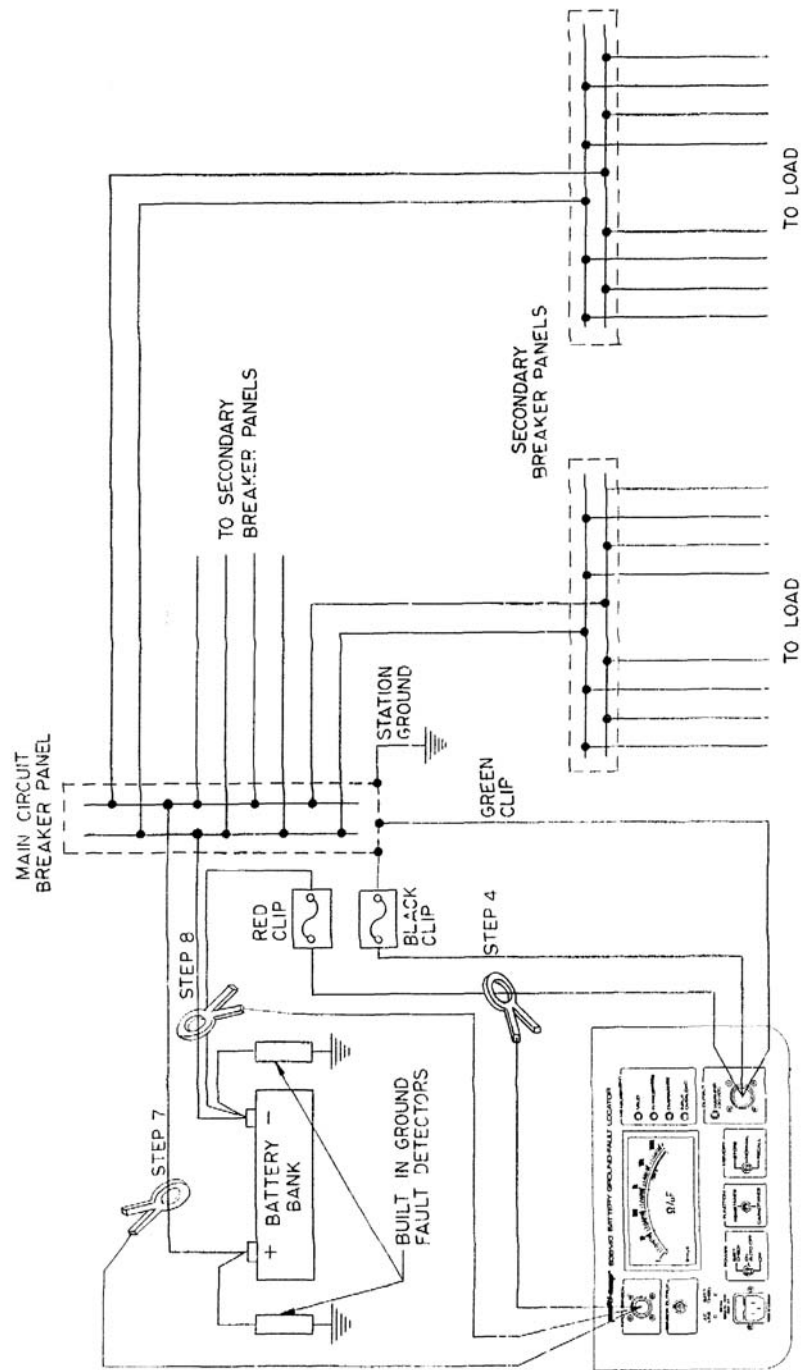

Figure 4-4: Detecting the Total Resistance and Capacitance to Ground

4.6 PROCEDURE FOR LOCATING GROUND FAULTS

Refer to Figure 4-5 for further clarification of procedure.

4.6.1 GENERAL

When attempting to find the location of a ground fault (or multiple faults), it is important to conduct the tests in a progressive and orderly manner. This means starting at a point closest to the battery (mains and mains breaker panel) and moving towards the individual loads.

The procedure used in Figure 4-5 outlines the steps required to locate a ground fault at its worst location. Following this procedure will typically take fewer steps to locate most faults.

When attempting to locate faults, some important items should be noted:

1. Once *red* fused clip is placed on a battery line it will inject an AC signal into both positive and negative sides of the battery system. This implies that this terminal, once connected to the system, need only to be removed when changing location. This has been used for the following procedure.
2. The procedure described is for the standard clamp-on C.T. If the mini-C.T. is used accuracy and maximum DC will change as per specifications.

4.6.2 STEPS TO LOCATE A GROUND FAULT

STEP 1 - CONNECTING INSTRUMENT

1. Connect *green* clip to station ground.
2. Connect *black* fused clip to station ground.
3. Connect *red* fused clip to NEGATIVE pole of the battery.
4. Clamp C.T. on *red* fused clip lead.

Indication on meter "3.33 Kohms", therefore, total resistance to ground is "3.33 Kohms". The 10k Ω grounding resistor must be in parallel to 5k Ω to get this value.

STEP 2

1. Clamp C.T. on positive battery lead.

Indication on meter "> 100 Kohms", therefore, no serious fault on the positive side of battery system is present.

STEP 3

1. Clamp C.T. on negative battery lead.

Indication on meter "5 Kohms", therefore, a total resistance of 5 Kohms to ground exists on the negative battery lead between the C.T. and all the connected loads.

NOTE: Grounding resistor 10k Ω is not seen by current sensor in this position, therefore the indication of 3.3 Kohms in step 1.4 increases to 5 Kohms.

STEP 4 - MOVE TO MAIN CIRCUIT BREAKER PANEL

1. Place red fused clip lead on main circuit breaker panel, NEGATIVE pole.

NOTE: It is preferred to inject the signal to the faulted pole of the battery. Hence the switch here from the NEGATIVE to the POSITIVE pole of the battery.

2. Clamp C.T. as per Figure 4-5.

Indication on meter "> 100 Kohms", therefore, no fault on this branch.

STEP 5

1. Clamp C.T. as per Figure 4-5.

Indication on meter same as step 4. Conclusion identical.

STEP 6

1. Clamp C.T. as per Figure 4-5.

Indication on meter same as step 4. Conclusion identical.

STEP 7

1. Clamp C.T. as per Figure 4-5.

Indication on meter "5 Kohms", therefore, the total resistance found in step 3 is somewhere on this branch between this point and the connected load.

STEP 8 - MOVE TO SECONDARY BREAKER PANEL

1. Connect black fused clip and green clip to station ground.
2. Connect red fused clip to POSITIVE battery lead in secondary circuit breaker panel.
3. Clamp C.T. as per Figure 4-5.

Indication on meter " > 100 Kohms", therefore, no fault on this branch.

STEP 9

1. Clamp C.T. as per Figure 4-5.

Indication on meter same as step 8. Conclusion identical.

STEP 10

1. Clamp C.T. as per Figure 4-5.

Indication on meter same as step 8. Conclusion identical.

STEP 11

1. Clamp C.T. as per Figure 4-5.

Indication on meter same as step 8. Conclusion identical.

It can now be stated that the ground fault lies somewhere between the Main Circuit Breaker Panel (step 7) and the secondary breaker panel (steps 8-11). More steps can be added to further pinpoint the location, but this will be up to the user.

Most battery systems have their own unique characteristics, by following this general outline, one should be able to develop his own plan on locating faults.

It is almost essential to have a thorough knowledge of one's battery system and its diagrams are essential for efficient ground fault location.

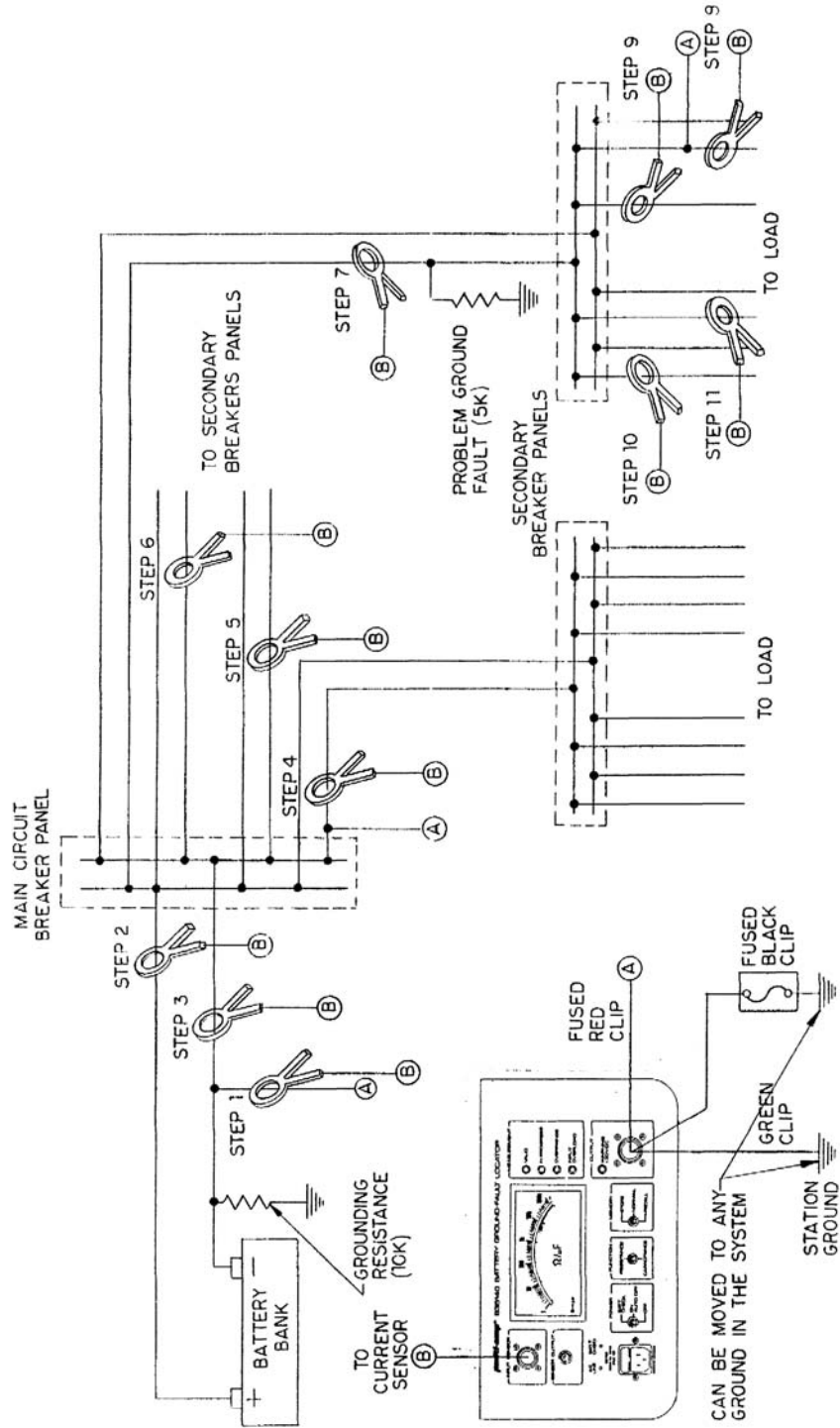

Figure 4-5: Locating Ground Faults

4.7 MULTIPLE FAULTS

Refer to Figure 4-6 for further explanation of procedure.

4.7.1 GENERAL

When dealing with older battery systems, it is very likely that more than one fault is present at any one time on the battery system. To locate multiple faults, it is important to note the exact values at each step and location. The resistance values are then compared to each other when all steps (1 to 11 in section 4.6) have been performed. This will allow the operator to determine if a fault is present between the test locations, or if the fault is closer to the load. If several feeders are faulted, they each will indicate the appropriate ground fault resistance, and these will combine to provide the equivalent parallel resistance, once they are connected together in a breaker panel.

As a general rule, when confronted with multiple faults, lower resistance faults must be eliminated first, before locating higher resistance faults.

EXAMPLE: STEP 1

1. Connect Battery Ground Fault Locator as per step 1 in section 4.6, *Procedure for Locating Ground Faults Leads and C.T.* as per Figure 4-6. Indication on meter "2.5 Kohms", therefore, total resistance after this point (including branches of secondary breaker panel) is 2.5 Kohms.

STEP 2

1. Connect *red* fused clip as per Figure 4-6, step 2.
2. Clamp C.T. as per Figure 4-6, step 2.
Indication on meter "5 Kohms", therefore, the resistance between the secondary breaker panel and load is 5 Kohms. This indicates a 5kΩ resistance between step 2 and step 1. All other leads will indicate > 100 Kohms.

One can calculate the resistance between step 1 and step 2 from:

$$\frac{1}{R_1} = \frac{1}{R_2} + \frac{1}{R_x}$$

where, R1 = Resistance measured in step 1.

R2 = Resistance measured in step 2.

Rx = Resistance between steps 1 and 2.

therefore,

$$\frac{1}{R_x} = \frac{1}{R_1} - \frac{1}{R_2} = \frac{1}{2.5k\Omega} - \frac{1}{5k\Omega}$$

and Rx = 5 Kohms

The resistance between secondary breaker panel and main breaker panel is therefore 5 Kohms.

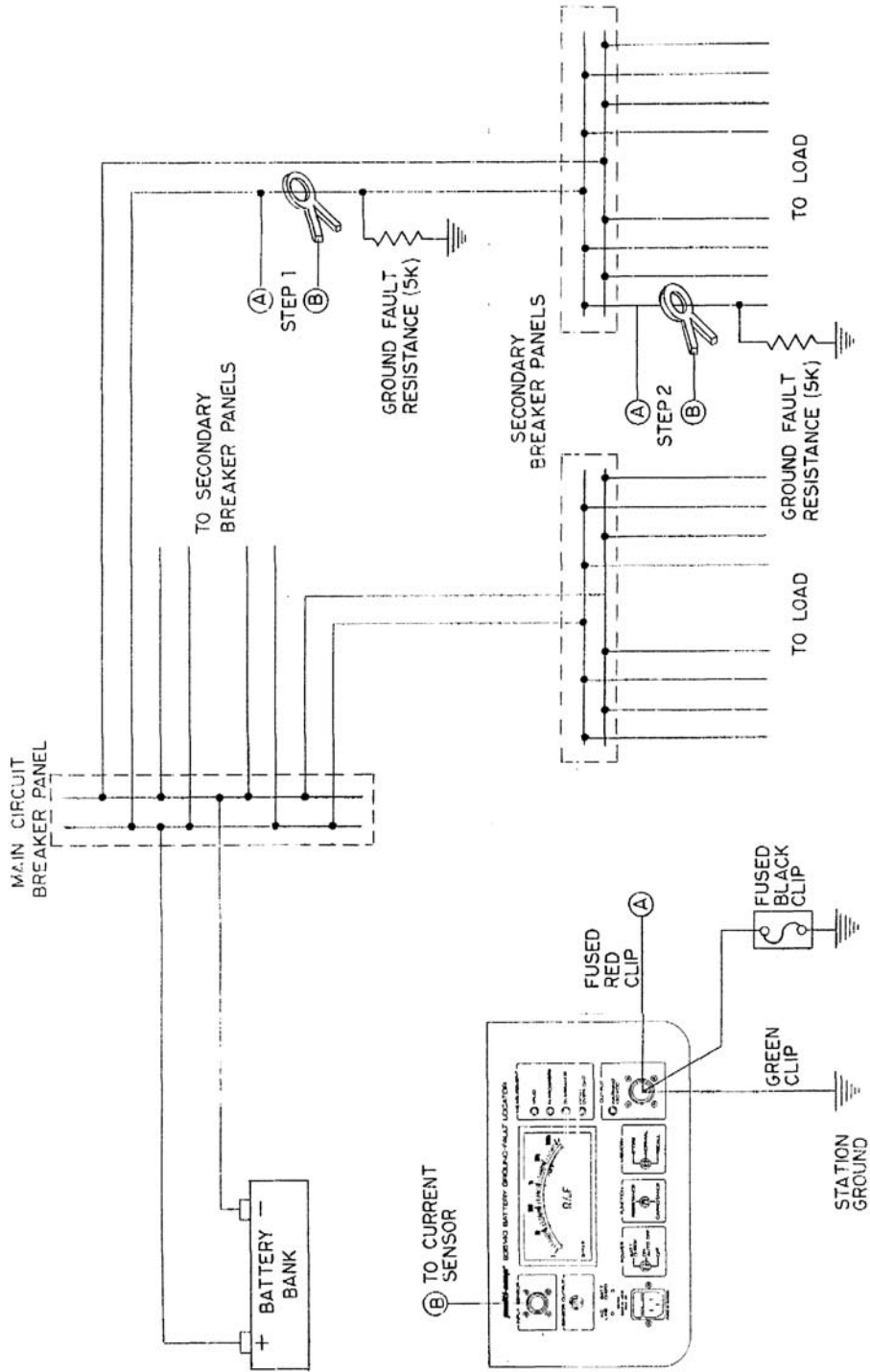

Figure 4-6: Locating Multiple Ground Faults

4.8 BATTERY SYSTEMS WITH CAPACITIVE LOADING (TRANSIENT SUPPRESSION)

Refer to Figure 4-7 for further clarification of procedure.

4.8.1 DESCRIPTON

Many loads connected to a battery system have a capacitor connected from each terminal to ground. Capacitors are placed on each load for transient protection. The value of capacitance on each load varies with the required degree of transient protection.

To measure the total or branch capacitance to ground, refer to section 4.4.3, *Measurement of Capacitance*.

When using a Battery Ground Fault Locator, the connected capacitance from the battery terminals to ground may affect the measured resistance values. The dissipation factor associated with the connected capacitor appears as a resistance to ground to the Battery Ground Fault Locator. The higher the loss in the capacitor, the lower the resistance to ground that is seen by the Battery Ground Fault Locator.

For most capacitors, dissipation factors are very low, so they appear as high resistance faults to ground. When conducting any ground fault location procedure, however, this possible source or error (or problem) should not be overlooked.

If the dielectric losses for a capacitor (or series of capacitors) are known, the effective "resistance to ground" can be calculated from the example below.

EXAMPLE: By definition:

$$DF = \frac{X_c}{R}; \quad \text{or} \quad R = \frac{X_c}{DF}$$

where, $X_c = \frac{1}{2\pi FC}$, F = frequency, C = capacitance, $\pi = 3.14$

therefore,
$$DF = \frac{1}{R \times 2 \times F \times C \times \pi}$$

or
$$R = \frac{1}{DF \times 2 \times \pi \times F \times C}$$

For a system where the capacitance to ground is 10 μ F and DF = 1% (0.01), the equivalent ground fault resistance will be,

835140
$$R = \frac{1}{0.01 \times 10 \times 3.14 \times 25 \times 2 \times 10^{-6}} = 64\text{Kohms}$$

835140-1
$$R = \frac{1}{0.01 \times 10 \times 3.14 \times 21 \times 2 \times 10^{-6}} = 76\text{Kohms}$$

From the results of this calculation, it can be seen that on its own, $10\mu\text{F}$ capacitance having a DF of 1% (0.01) will register on the Battery Ground Fault Locator. This may not always be the situation, as the DF of capacitors used for this application should be higher than 1%.

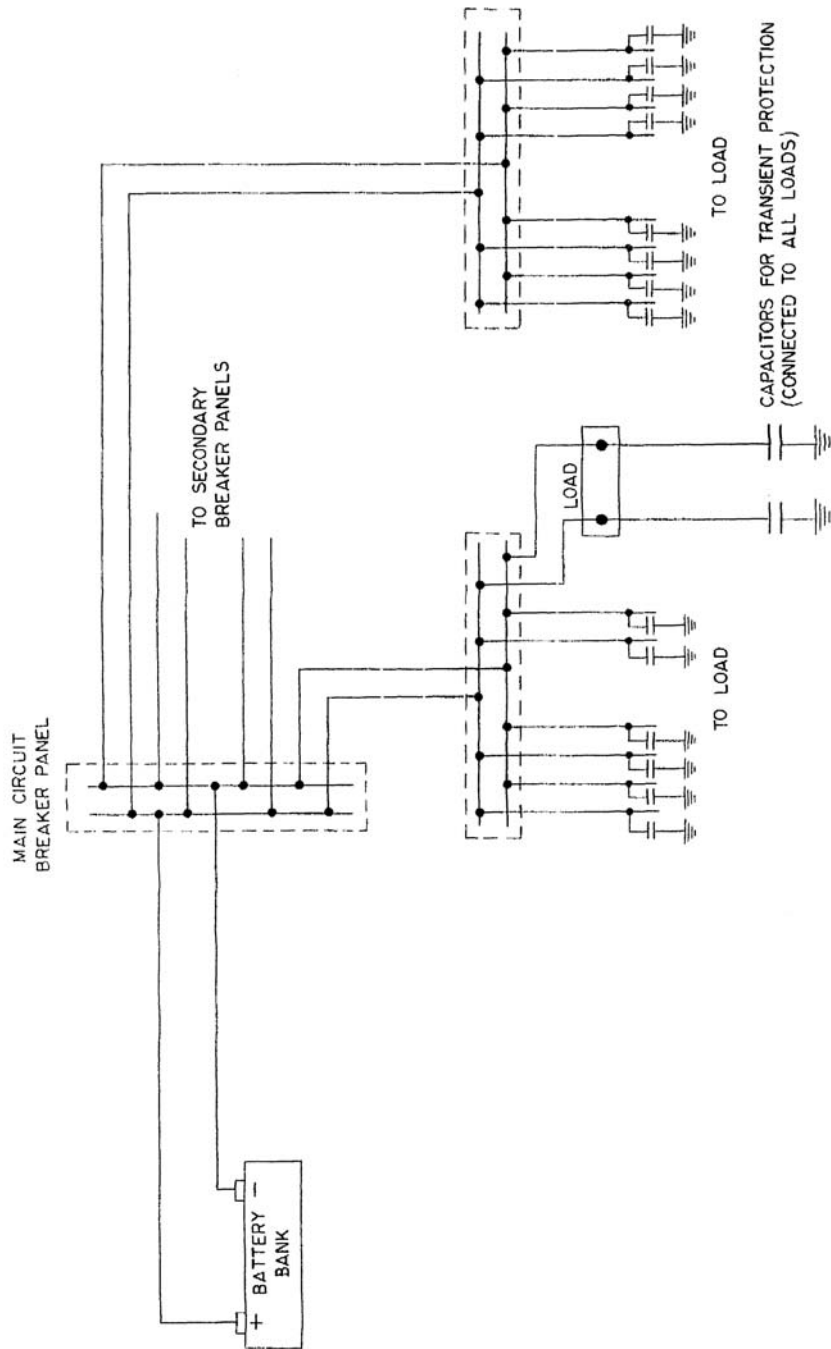

Figure 4-7: Battery System with Capacitive Loading

4.8.2 ACCURACY vs CAPACITIVE LOADING

The instrument's ability to resolve the resistive signal component deteriorates with an increase of capacitance in the measuring loop. This is mostly due to phase angle uncertainty in the instrument. Below is a table which can be used as a guideline when the operator wishes to determine the highest resistance value that can be measured with reasonable accuracy, in the presence of capacitance.

For ±20% Error Limits	
100KΩ	0 - 1μF
100K - 50KΩ	1 - 2μF
50K - 20KΩ	5 - 10μF
20K - 10KΩ	10 - 20μF
10K - 5KΩ	20 - 50μF
5K - 2KΩ	50 - 100μF
Lower than 1 KΩ	Larger than 100μF

Table 4-1

4.9 BATTERY SYSTEMS WITH SWITCHING LOADS

Equipment essential for the operation of an electrical power system, is usually powered by station batteries. Some of this equipment draws power from the battery system only momentarily. An example of such a load is shown in Figure 4-8. The annunciator lamp load shown is especially severe as the lamps draw a heavy in-rush current on "Turn on".

The current waveform in Figure 4-8, when broken down into its harmonics, is made up of 3Hz + 5Hz + 7Hz + 9Hz . . . + 25Hz, etc. When the BGL is tracing a leakage current it is sensing the 25Hz current component. The 25Hz component from momentary loads may interfere with the resistance measurement, depending on its magnitude.

The results of this interference will be a fluctuating meter on the BGL. The meter will swing back and forth in a cyclical manner. This erratic behavior will result in an inability to resolve resistive ground faults on this particular branch.

The BGL is protected against many annunciator and switching load problems by way of a special "sample & hold" circuit. This circuit however, may not work under all conditions, and the removal of an interfering load may be necessary for effective ground fault location.

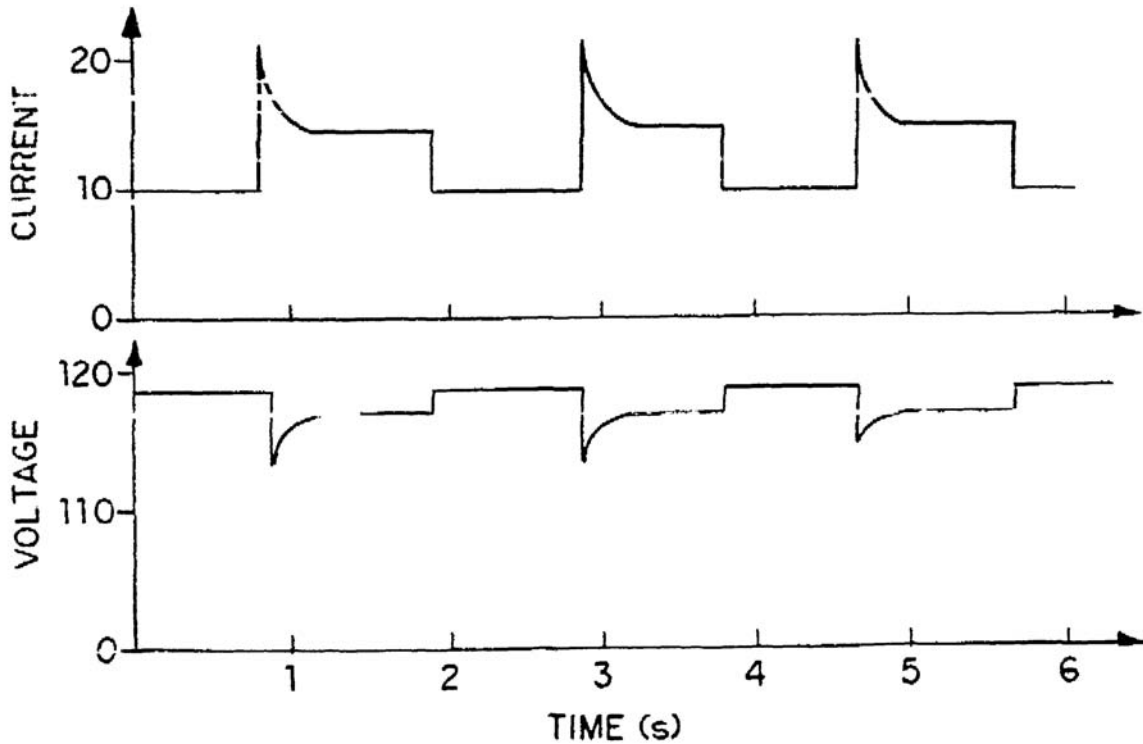

Figure 4-8: Waveforms with Switching Annunciator Lamp Load

4.10 POWER FREQUENCY AND HARMONIC RIPPLE

Power frequency and harmonic currents may be induced in the wiring of a battery system in a variety of ways. The primary source of such currents comes from unfiltered battery chargers.

There are a variety of SCR controlled battery chargers used by utilities which do not have an output current filter. When such battery chargers are combined with a system wide application standard of surge suppression capacitors, the harmonics

permeate the entire battery system, and their magnitude may exceed the 0.5 amperes (rms) tolerated by the BGL.

It should be pointed out that the BGL is sensitive to the peak of the ac current, which should not exceed 0.7 amperes, approximately.

The "INPUT OVERLOAD" LED will illuminate when saturation is experienced, and readings cannot be considered as "VALID".

The turning off of offensive battery chargers, or other equipment, is necessary if one wishes to continue the tracing of battery ground faults.

4.11 SENSOR OUTPUT

When encountering "INPUT OVERLOAD" the trouble shooting problems can be greatly simplified by using the "Current Sensor Output" connected to an oscilloscope.

The "Sensor Output" provides a replica signal of the current sensed by the clamp-on sensor. Absent from this replica is DC, and the injected 25Hz (21Hz for 835140-1) current components. This output should be examined in all situations when "INPUT OVERLOAD" occurs, so that reasons for this condition can be determined and eliminated. When recorded, this output can be used by the utility engineers or Megger to find out why, and where, problems are originating from, and how to eliminate or avoid them.

In some cases, the amount of ripple observed will give the operator an immediate conclusion to the source of a problem. This is especially true if the ripple frequency matches the line and battery charger ripple.

5

SERVICE AND MAINTENANCE

The Megger Battery Ground Fault Locator incorporates complex circuitry. As the specialized test and trouble-shooting equipment is not readily available to the field user, a complete detailed circuit operating description would be of little use and has not been supplied.

Field service and calibration requirements should be referred to the nearest Megger sales office.

Megger[®]

6

DOCUMENTATION

The following drawings are included at the end of this section for reference purposes only.

DRAWING NUMBER	TITLE
C35140-102	Schematic, Chassis
C35140-103	Block Diagram, Chassis
A35145-101	Schematic, Fault Simulator

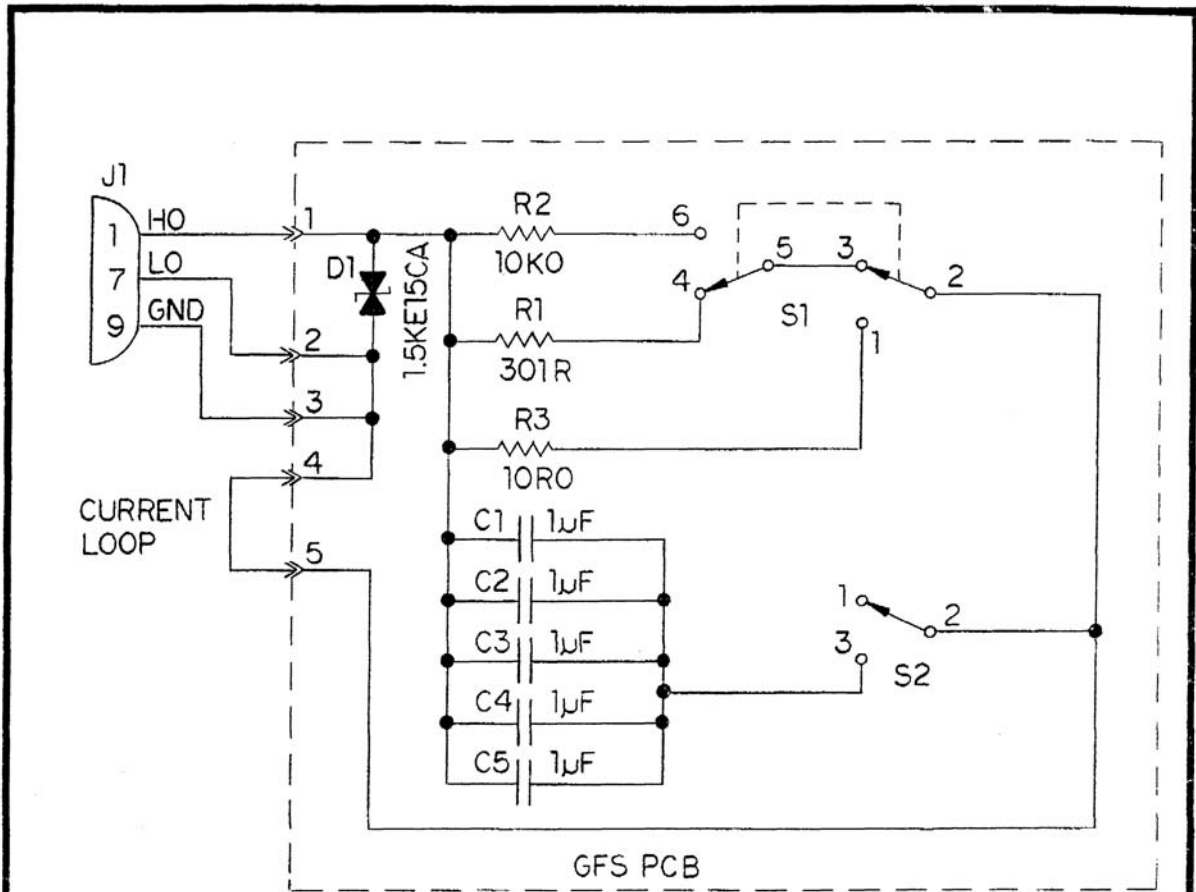

NOTES:

1. ALL RESISTORS ARE 1/2W, 1%
2. ALL CAPACITORS ARE 100V

REV	ECN	CHANGE	S/N & UP	DRAFT	ENG	CHECK	APPR	DATE
MATERIAL:		ALL DIMENSIONS ARE IN INCHES/mm. DO NOT SCALE DRAWING DEBURR AND BREAK SHARP EDGES UNLESS NOTED TOLERANCES ARE .X ± .100 .XX ± .020 .XXX ± .005 ANGLES ± 0.5°	DRAFTED: A.S		CANADA LIMITED TORONTO, ONTARIO			
FINISH:			ENGINEER: LM					
35145		M. A. C. P/N:	SHEET: 1 of 1	APPROVED: KD		DRAWING NUMBER: A35145-101		REV.
USED ON		S/N & UP: 5803	SCALE: 5803	DATE: 89 11 or				

NOTICE: THIS DRAWING IS THE PROPERTY OF MULTI-AMP CANADA LIMITED AND ANY DISCLOSURE OF ITS CONTENTS TO OTHERS IS GIVEN IN